

THE ECHO

Created by incarcerated people

NEWS
FROM
THE
INSIDE

WINNER OF AMERICAN PENAL PRESS AWARD FOR BEST NEWSLETTER 2025

VOLUME IX | ISSUE 90, MAY 2026

EASTERN OREGON CORRECTIONAL INSTITUTION

2500 WESTGATE

PENDLETON, OR 97801

EST. 2018

PERSONAL TABLETS AND MAIL SCANNING

Incarcerated People Have Mixed Reactions to Upcoming Changes

Written by Kurtis Thompson

Tablets will be issued to all adults in custody, according to the Director’s Office for the Oregon Department of Corrections. Additionally, they plan to process almost all incoming mail for incarcerated people digitally by year’s end.

The change is intended to reduce drug smuggling into institutions and to meet statewide budget reductions.

According to the department’s 2025-2027 budget proposal, shifting away from most physical mail will save the state about \$500,000 per biennium. While this is good for the state, opinions of incarcerated people are divided.

Oregon prisons already have some tablets available for incarcerated people to check out. Jacob Morris, who has been incarcerated since 2021, said he uses the free educational applications almost every day.

See TABLETS page 2



Service Dog Training Program Celebrates Milestone

Written by Chris Ainsworth

Photo by Chris Ainsworth/The Echo

Service canine Betsy from the JLAD program sleeps while trainers and program staff celebrate 10 years of operation in the correctional setting.

In 2015, Jeff Frazier drove six hours to Salem to propose a first-of-its-kind program to Oregon Department of Corrections. Frazier, then a Captain at EOCI, was proposing a program that would allow incarcerated individuals to train service animals. The first six puppies arrived at EOCI in 2016.

On April 10, 2026, the Joys of Living Assistance Dog program celebrated

an unprecedented milestone – their 10-year anniversary working inside the facility. The celebration, held in the multipurpose building, showcased incarcerated and staff speakers, recognition for trainers, and service dog demonstrations. The trainers and their families, previous service dog recipients and administrative staff shared laughs, and even a few tears.

See JLAD page 6

ONE YEAR OF PRISON
BREWS Page 3

ENRICHMENT CLUB PLANS
STEAK MEAL Page 4

PEER WELLNESS MENTOR
PROGRAM STARTS Page 18

JOURNALISM DEPARTMENT
WINS AWARDS Page 32



The Echo Team

Phillip Luna | Editor-in-Chief

Kurtis Thompson | Associate Editor

Chris Ainsworth | Writer-at-Large

Logan Gimbel | Design and Layout

Brian Daniel Bement | Correspondent

Alex Dewhurst | Correspondent

Jamil Chavis | Correspondent

ODOC Staff Support

Ray Peters | Supervising Editor

Advisor

Berit Thorson | East Oregonian, Journalist

The Echo Mission Statement

To serve the incarcerated community by providing monthly news and other important information, while highlighting the human experience in the carceral setting.

Direct questions and comments to EOCI Institution Work Programs (IWP). All views and opinions expressed are those of the contributing writers and do not necessarily reflect the views of the Department of Corrections.

The Echo grants permission for publications outside of the Department of Corrections to reprint articles, with appropriate credit given to the writer and the publication, except where articles are sourced from other publications.

Sponsored by



www.pollenpress.org

AROUND EOCI

TABLETS CONTINUED FROM PAGE 1

“I don’t use messaging, though, because I can’t afford it,” he said. “I only make about \$40 a month.”

The tablets came from ICSolutions, a telecommunications company the department contracted.

Their tablets have two different modes incarcerated people can log into – one is free, the other costs 4 cents per minute. Applications such as messaging, games and streaming services are available on the paid side. In order to use messaging, AICs must pay per minute to send or read a message. It also costs a person outside prison 25 cents to send a message.

“It would be nice if messaging were on the free side,” Morris said. “My aunt wants me to message her, but I just can’t afford to. All my money goes towards things I need on canteen.”

Ten minutes on the messaging application is 1% of Morris’ monthly income. But, according to the department’s answers in their online tablet Q&A, messaging costs may change. Instead of paying per minute, incarcerated people and those outside prisons may pay per message instead. Terms are still being negotiated.

Messaging aside, some questioned digital mail processing. The department said physical mail, excluding legal mail, publications and packages, will be scanned. It is unclear if the scanning process will impact delivery times.

“There’s so many things that bothers me about scanned mail,” said Jerry Lutcavich. “Will our mail take longer to reach us since they’re scanning it? What about photos? Having a digital picture might work for people outside prison, but holding a photo of my family means a lot to me.”

Morris, on the other hand, said mail scanning will not affect him.

“I don’t usually get mail or photos,” he said. “I usually call or have video

visits with my family. I think a lot of us are just concerned about the pricing. Are they going to charge us to view our own mail?”

In the department’s Q&A responses, they said scanned mail will be viewable for free.

However, mail delayed by third-party scanning may have other consequences. According to Leah Wang, a senior research analyst for the Prison Policy Initiative, delays sometimes push people to use paid communications more.

“Compared to mail that’s delayed due to scanning procedures, or scanned incorrectly, incarcerated people and their loved ones often understandably switch to electronic messaging ... phone calls or video visits,” she wrote in a 2022 report.

But while many concerns are centered around mail delays and pricing, administrators are exploring options to reduce communication costs for incarcerated people.

“Early planning shows examples of fee monthly minutes, messages, or calls in some scenarios, but these are not final,” the notice said.

Incarcerated person Jacob Anderson, however, remains skeptical.

“It’s going to be a struggle,” he said. “The [current] systems are always crashing, there’s always problems.”

The current tablets use local Wi-Fi. At EOCI, some areas have inconsistent signal, often disconnecting the tablets unexpectedly.

“The other thing to take into account is not every family is tech-savvy,” Anderson said.

The department said their goal is to “improve access to communication, not reduce it. Facilities will provide instructions, orientation materials and support” during the rollout. | ECHO

ONE YEAR OF PRISON BREWS

Prison-Run Coffee Shop Celebrates Anniversary, Aims to Expand Services in 2026

Written by Chris Ainsworth



Photo by Chris Ainsworth/The Echo

Shane McGann delivers coffee orders to the visiting room on March 20, 2026. Prison Brews coffee shop began selling to incarcerated people in the visiting room and their visitors in September 2025.

April 2 marked the one-year anniversary of Prison Brews, a coffee shop at Eastern Oregon Correctional Institution staffed by incarcerated baristas.

Prison Brews – named as a play on words of Prison Blues, a clothing brand made in EOCI’s garment factory – served more than 7,000 cups of fresh-brewed deliciousness in its first year.

Menu options were scaled slowly as the incarcerated workers went through training and developed their skill sets throughout the year. Their week-long initial training began in March 2025, led by Kirby and Winston Hill, the owners of local coffee shop and roaster Buckin’ Bean.

Eight incarcerated people and one staff member went through the training.

“The training initially felt a little

intimidating, but honestly it was more just getting in the groove,” kitchen clerk and barista Michael Morris said.

Additional drinks were added to the menu over time – more than 25 syrup flavors and eight sugar-free syrups are currently available. Prison Brews also offers four Big Train brand premixed frappuccino flavors, six smoothie flavors and four Lotus flavor options – a plant-based energy drink. The shop also offers a small selection of pastries and bagels.

Limited beverage options became available to adults in custody and their visitors in September 2025. In the last four months of 2025, the shop delivered more than 1,200 beverages to the visiting room.

There are fewer visitors in winter, but Prison Brews still delivered almost 500 drinks in the first three months of 2026.

“A lot of friends I have here said their families loved the coffee. The AICs love it,” said Morris. “I haven’t gotten any bad feedback.”

As a kitchen clerk, Morris helps behind the scenes of Prison Brews. He fills in when the coffee shop is short staffed, but also manages inventory for the shop.

“Trying to learn how to manage inventory is a bit of a struggle,” he said.

Morris also created cheat sheets for baristas to ensure consistency in their drink making.

In addition to developing job skills, AICs have the opportunity to work in a real-world environment. The shop also provides an opportunity for AICs and staff members to have normalized interactions.

“This is a better work environment overall, definitely more like a job would be on the outside,” said Adam Elias, Prison Brews’ newest team member. “Staff come in and are happy to see you. You have great conversations, versus on a unit where an officer is dealing with 80 people and not having a good day because of it.”

“The baristas get a break from their regular routines while learning job skills,” said Office Support Specialist Tami Clark. Clark went through the barista training with the AICs and helped manage the shop in its first year. “It’s more like a job on the outside – working on customer service and treating people kindly.”

In 2026, the coffee shop hopes to deliver coffee orders to officers on unit or in other areas. Additionally, the shop hopes to sell coffee to Level 3 AICs.

“Eventually, we want to sell to the Level 3’s in the institution,” said Liza Emory, acting food services administrator.

if approved, Emory said she believes the shop can begin selling coffee to AICs by the end of 2026. | **ECHO**

AROUND EOCI

ENRICHMENT CLUB PLANS STEAK MEAL

Club Returns to Kitchen After an Almost Two-Year Gap

Written by Alex Dewhurst



Photo by Phillip Luna/The Echo

Steaks on a flat top grill from the Enrichment Club's last steak fundraiser in 2024.

The Enrichment Club, EOCI's fundraising group, plans to sell a steak and kielbasa meal to raise money for the Children's Organ Transplant Association.

"Just about anybody can get on board for donating money to an organization that does organ transplants for children," said Enrichment Club President Ben Edwards.

He said the club is still waiting for approval from staff, but they plan to sell the meal for \$36 per person. Edwards said the club plans the meal to include a 12-ounce ribeye steak, 16 ounces of kielbasa, deep-fried mozzarella sticks, marinara sauce, two sodas and chocolate chip cookies from the bakery.

Fundraiser flyers will be posted on housing unit bulletin boards in May, he said.

The deadline for orders is expected to be June 5 and limited to 600 incentive Level 3 incarcerated people.

Edwards said the meal will be cooked on site by Recreation Specialist Jerrad Templin and Enrichment Club members. He expects the handout to be July 9.

"We would like to make the steak feed an annual thing," Edwards said. "So that way, the population knows every single summer you need to stay out of trouble because there is going to be a steak feed at some point."

The club has no set annual fundraisers, but the two previous fundraisers for COTA in 2024 and 2026 were popular.

Edwards said the biggest donation the club made for COTA was more than \$9,000.

"It was for a local little girl's heart transplant," he said.

GETTING BACK TO BBQ

For the upcoming fundraiser, food will be prepped in the facility.

"We are excited to get back to using

The club plans for the meal to include a 12-ounce ribeye steak, 16 ounces of kielbasa, deep-fried mozzarella sticks, marinara sauce, two sodas and chocolate chip cookies, priced at \$36 per meal

the grill and use some of Templin's skills," he said. "He's won barbeque competitions across the country."

Edwards said a policy change prevented the club from using the facility's kitchen in 2024 and 2025. That policy has since relaxed and the club is able to use the kitchen and grill again.

"We really got ahead on this one when we learned we can use the barbeque again," he said.

Then Food Services Manager Liza Emory and Assistant Superintendent Bryan Clark were influential to getting the barbeque back, Edwards said.

"They all went to bat for us and we got it back," he said.

Edwards said meals made in the institution's kitchen are less expensive and more money goes to charity because the club does not have to pay for labor; they rely on volunteers. Ordering food from Domino's, for example, means the club has to pay for labor,

LOP LINES ADJUSTED

Lines Standardized, Increased to 30 Minutes

Written by Phillip Luna

The LOP schedule has changed.

LOP, or Loss of Privileges, is status an adult in custody can be placed on for disciplinary reasons.

When an incarcerated person is on LOP, they lose access to common areas and are restricted to their cell or housing area for the duration of the status. They still attend meals and appropriate call outs, but daily activities, such as showering or using common areas are restricted.

Previously, a person on LOP could only access the common areas during a LOP line, which was set at the discretion of the on-unit officer.

For an incarcerated person sanctioned to LOP, that meant an unpredictable schedule. Additionally, the line movements were usually restricted to five minutes.

In a memo from Operations Captain Paul Miller, he said the change will standardize LOP lines. The time has been extended to 30 minutes. The morning line will be from 7:25-7:55 a.m. and the evening line from 5:25-5:55 p.m.

The memo said that during a LOP line, “[AICs] may check callouts, take a shower, get water, obtain a library book or complete other routine needs.”

“As part of the continuing effort to promote the wellbeing of AICs mental health,” said Assistant Superintendent of Security Tye Stewart, “we determined that we should allow AICs on LOP more out-of-cell time.”

The change will allow people on LOP status more time to complete daily tasks. | **ECHO**

INCREASES TO POSTAGE PRICES

Normal Envelopes Unaffected, Larger Envelopes May See Price Increase

Written by Kurtis Thompson

Postage prices are increasing for some parcels, according to the U.S. Postal Service. According to their press release, the cost increases are temporary. The price change will go into effect on April 26 and remain in place until Jan. 17, 2027.

The increases will only affect the cost of mailing packages, such as books, guitars and other like items. Standard #10 envelopes from canteen are not affected. However, according to ODOC administrators, larger envelopes from canteen may be affected because USPS treats those as packages.

Also, even though price hikes are set to expire, USPS said they will reevaluate whether “a different long-term approach is needed,” according to the release.

“Transportation costs have been increasing, and our competitors have reacted with a number of surcharges,” the release said. | **ECHO**

PRODUCT RECALL

Return Eyedrops to Commissary for a Full Refund

Written by Kurtis Thompson

In April, GoodSense Eyedrops issued a product recall for their Ultra Lubricant Eyedrops, sold on canteen.

According to the recall notice, there was concern with the manufacturer’s aseptic filling process, which is how the bottles are filled. The recall indicated use of the drops may cause an eye infection.

According to the recall, people with this product should stop using it immediately. The Ultra Lubricant Eyedrops bottles with product numbers SU24E01, SU24E02 or SU24E03 on

the label may be returned to canteen for a full refund, even if partially used.

“We were rushing to find a replacement company for the eyedrops, and I think we found one, but we don’t have the product in stock yet,” canteen staff member K. Bomberger said. “If you have the recalled eyedrops, just send me a kyte and we’ll get you down here for a refund.”

GoodSense is one of many companies who have recalled their goods. Between 2014 and 2024, 83,000 products were recalled, according to the

Food and Drug Administration.

Recalls are typically made for reasons serious enough for businesses to spend thousands of dollars collecting the product and refunding customers.

According to the FDA’s website, recalling defective goods protects “the public from products that may cause injury, illness or even death.” The recalls may be voluntary by the company or are made by FDA request.

For more information on recalls, those outside carceral facilities can check the FDA’s Enforcement Report at <https://www.accessdata.fda.gov/scripts/ires/index.cfm>. They can also sign up for recall notifications at <https://public.govdelivery.com/accounts/USFDA/subscriber/new>. | **ECHO**

AROUND EOCI

JLAD CONTINUED FROM PAGE 1

Photo by Chris Ainsworth/The Echo

Former EOCI Superintendent Jeri Taylor, left, and ODOC Deputy Director Heidi Steward watch service dog Freya execute a command from trainer Jesus Villarreal during the dog training program's 10-year celebration on April 10, 2026.

"I got a lot of kickback back then. People telling me, 'I should not go down this road. I am not in a safe place; it's a men's prison,'" JLAD founder Joy St. Peter said to the crowd. "I have never once ever felt compromised, threatened or anything else like this."

"I am really happy to prove everybody wrong, because there are some really good people in here," she added.

The event's master of ceremony was Jesus Villarreal, an incarcerated person and service dog trainer since 2021. Villarreal introduced speakers and narrated the event.

Prior to being accepted into the program, Villarreal said he lacked direction, responsibility and empathy. He was indifferent to rules and lived in criminality. He is thankful for the opportunity and the purpose JLAD has given him.

"Joy and the EOCI admin have provided me with a chance to find my true self," said Villarreal. "I can be of service to others, be it training dogs for

people with disabilities or training other people. I have learned to be accountable for more than just myself."

The first speaker, trainer Larry Wilt, started his speech while slowly raising his hands to chest level.

"I don't know what to do with my hands," he said, referencing a famous scene from the movie *Talladega Nights*.

After introducing the bit of levity, Wilt talked about how the program impacted him and others. The speech left many, including himself, wiping tears from their eyes.

"If you met one of these trainers, would you have thought to yourself, 'I think I will teach them to put another's needs above their own'? It's a leap," Wilt said. "These dogs really are amazing and they work wonders. It's a labor of love."

St. Peter labors for the program, Wilt said. She drives eight hours nearly every Monday to meet with the trainers and works with them to improve their

skills. She changes their lives by treating the trainers like people, he said.

Trainers said her positivity has made difficult times more bearable – and one event stood out.

In 2025, following complications from a difficult pregnancy, the JLAD program lost Moxie, one of their breeding females. She had been born and raised at EOCI, well known by everyone. Her death affected many.

"After all the hard blows life dealt out last year, more than enough for anyone to wave a white flag in surrender, Mrs. St. Peter, you showed up," Wilt said through tears. "You showed up for the dogs, you showed up for your team and, as always, you showed up for the recipients."

The event also recognized a handful of trainers for their continued work with the program. In total, six AICs received certificates. Most of the certificates were handed out to trainers who have been with the program for two years. Federico Jimenez, however, was the only AIC recognized for being with the program since the very beginning.

"When he first started in the program, it was difficult to get him to participate in the group settings. He was always by himself and wouldn't talk much," said St. Peter of Jimenez. "Now, he is one of our top facilitators and has been a great mentor for many of the guys here."

"Ten years ago, Joy and Frazier took a chance on me when I never thought they would," Jimenez said. "I was deeply humbled. Thinking about it makes me emotional. I want to cry and inspire others at the same time."

Many speakers talked about how St. Peter has touched their lives. Villarreal recounted a moment where she told him it wasn't the things in front of him that was the problem, but the things inside him holding him back. He said



Photo by Chris Ainsworth/The Echo

Service dog trainer Paul Adric and service animal Allie stare at a cake made by the EOICI bakery for the JLAD celebration on April 10, 2026.

he plans on taking the skills the program has taught him wherever he goes. Many shared Villarreal's sentiments.

"JLAD saved me. It gave me a second chance at life," said Charlie Kygar. "It's a humbling experience. I have the trust of Joy and the administration. It makes me feel like I'm a human, not just a prisoner."

Trainers put on a demonstration for attendees during the celebration. When the program began, the training included 35 cues. Now, the service animals are trained in nearly 100.

During the demonstrations, dogs retrieved items on command, including medicine, water and a mobile phone. The animals also helped trainers remove clothing, such as socks, and placed the items in a laundry basket.

The dogs have been trained to respond to panic attacks or night terrors by comforting their owners. They also demonstrated their ability to get help for their owner in an emergency. During the training demonstration, one of the service dogs retrieved St. Peter

from where she sat in the audience watching the demonstration – an unplanned moment.

For most of the event, St. Peter sat with board members and other JLAD staff watching the demonstration. She

was joined by Frazier who, after nine years of working with the program from inside the prison, retired in 2025. He is now a member of the JLAD board and a socializer.

Socializers take the service dogs for a few weeks at a time to give them experiences outside of prison, such as going to stores, businesses or parks.

Ten years after Frazier made the trip to pitch the program, a group of ODOC officials embarked on the six hour trek from Salem to Pendleton to celebrate the milestone. The group included the department's director, Mike Reese; the assistant director, Gail Levario; the deputy director, Heidi Steward; and the department's chief of staff, Jen Black. They remained after the presentations, interacting with trainers and staff.

"It was nice to see all the people show up in support," said Villarreal, after showing Steward some of the cues his service dog has learned. "It felt like I was part of something positive. Giving back to other people with these dogs has made doing my time worth it." | EOICI



Photo by Chris Ainsworth/The Echo

Founder of JLAD, Joy St. Peter, speaks at the podium during the program's 10-year celebration on April 10, 2026.

AROUND EOCI

BEEKEEPING PROGRAM KICKS OFF YEAR 7

New Bees Arrive Through the Mail; Program Hopes to Add a Queen Rearing Operation

Written by Logan Gimbel with contributions from Phillip Luna



Photo by Chris Ainsworth/The Echo

One of the bee packages is placed into a hive in the EOCI apiary on April 9, 2026. Several bee program students attend the package installation.

The prison gained 30,000 new residents on April 9.

Packaged in three, white plastic boxes, honey bees could be heard buzzing from several feet away. Each box contained 10,000 bees and a queen. The bee packages were purchased from Mann Lake, a beekeeping company in California, and delivered by mail to the prison's beekeeping program.

The program overwintered three hives from last year; the packages will double the size of the apiary. Additionally, the overwintered hives are likely to be split this coming season, further increasing the number of hives. A split is the process where a beekeeper takes a highly populated hive and manually divides it into two or more hives.

The bee packages were installed in the apiary, just east of H building. Sev-

eral students attended the event as this seasons beekeeping facilitators — Brett Lloyd, Scott Steffler and Joe Tuttle — gave a demonstration on how to install a package of bees. The beekeeping program is a peer-led class.

“Once you get enough bees together, they pour like water,” said Lloyd.

They poured each package into its own hive, which they had outfitted with bee frames and resources to help the hive develop.

One by one, Steffler opened the packages and installed the bees.

In general, bee hives are purchased either by package or in a nucleus hive. Packages contain bees, a queen and limited food sources. A nucleus hive is a box with five frames, bees and a laying queen. Packages are usually less expensive, about a few hundred dollars,

but take more time to develop into a honey-producing hive.

Inside the package the queen bee is separated in a small, screened-in box, called a queen cage. Often the bees and the queen come from different locations and the separation is necessary. Bees may attack an unfamiliar queen if they have not adjusted to her pheromone.

Steffler removed the cap on the queen cage, exposing a plug made of fondant—a type of sugar candy—that prevented the queen from leaving her cage and then suspended her in the middle of the hive, wedged between two frames. It can take a few days for workers to eat through the fondant, releasing their queen. However, the de-

lay allows the hive to acclimate to her pheromones.

The bees ordered this year are Carniolan, a species known for their exceptional gentleness—usually only stinging in defense of the hive. Originally from the European Alps, Carniolans are also better adapted to the cold.

As the hives are installed, students in the program will be partnered with an experienced beekeeper and assigned a hive to manage for the season.

“I never thought I would be able to do something as amazing as handle my own hive,” said student Paul Adric.

A healthy, productive queen will lay about 2,000 eggs a day.

“We may have almost half-a-million bees this summer,” said Lloyd.



Photo by Chris Ainsworth/The Echo

Beekeeper Scott Steffler holds one of the newly received queens up for attending bee program students to see on April 9, 2026.

A queen can live for three to five years, but sometimes a hive loses the queen early because of predators, disease, mismanagement or a number of other reasons.

REARING NEW QUEENS

The beekeeping program, which started in 2019, is adding another layer to their apiary this season. They are hoping to develop a queen rearing operation.

“We are probably the only institution in Oregon that is trying to raise queens,” said Lloyd. “The goal is to use the queens to start new hives instead of ordering packages.”

Located in the greenhouse and separate from the apiary, the beekeepers have a hive they are using to develop queen bees in a process called queen grafting. They use a specialized tool with a tiny scoop to carefully removed a day-old larvae — about the size of a grain of rice — and place them in a queen cell.

In a typical hive, the bees will create queen cells and leave them empty until

they are needed. Should their queen become compromised, the hive will relocate a larva to the cell.

The larva is provided with special nutrients and food sources by the bees and will develop into a queen.

The beekeepers are essentially trying to manufacture the production of a queen by taking multiple queen cells and manually relocating a larva into each cell. The goal is to trick the hive into producing queens, which can be used in splits or as replacements for existing hives.

“Sometimes we would go to inspect a hive and the queen would be missing. We have no idea where she went,” said Lloyd.

Losing a queen is a major setback and although the hive can usually produce a queen on its own, the process stymies honey production and can be detrimental to overwintering the hive. It can take more than a month for a queenless hive to get back on track.

According to Steffler, a new unmated queen has a 25% chance of failing to return to her hive after mating. This may be one reason why a queen could be missing.

Whatever the reason, the beekeepers hope to have queens produced and ready should the need arise. **ECHO**



Photo by Logan Gimbel/The Echo

Carniolan honey bees gather around a caged queen on April 9, 2026. The queen is new to the workers and is caged while they acclimate to her pheromone.

AROUND EOCI

LIBRARY PUBLISHES BOOK CATALOG

Work-in-Progress Catalog Already Has 15,000 Titles

Written by Kurtis Thompson

In November 2025, the Law Library at EOCI uploaded a list of law-work resources available for checkout to institution tablets.

More than 200 resources are available. The General Library has also been working on a catalog since January 2025, but this project is much larger—by about 15,000 titles.

“The master catalog is old and has about 30,000 publications listed,” said Library Coordinator Mary Muñoz. “People have been adding titles to the list, but nobody ever took titles out when books were lost or removed from circulation. Our library clerks have been going through the catalog title by title to see what’s actually here.”

The General Library has been uploading their catalog as they complete it. The book list can be found on the

free side of institution tablets in the notifications application. The list is still growing as there are about 4,000 books left to organize across 14 genres.

According to library clerk Charles Thornberry, the workers spent more time verifying what books were present rather than what is missing. He said it is difficult to track down missing books because when residents are released, transported to other facilities or taken to disciplinary segregation, books in their possession are sometimes not returned to the library. This slowed the cataloguing progress, but Thornberry said he hopes they will be done this year.

“We’ve been going through tons of books, getting them organized into categories so people can find them more easily,” Thornberry said. “We’ll hopefully be done by fall.”

But the cataloguing will never be truly complete. According to Muñoz, the library receives between 100 to 150 book donations per month. The catalog will be periodically updated on institution tablets, she said.

Incarcerated people interested in checking out those books may contact the General Library with a list of up to five titles they want to read. Some titles are popular and may not be immediately available.

Thornberry also said if a book in a series is missing or unavailable, the librarians may jump to the next requested book.

Only one book may be checked out at a time per week.

“At your next scheduled callout, you may request an additional week. Extensions are one week only – other people may be waiting for that book,” Muñoz said. “Those who repeatedly miss callouts to return books may be restricted from checking out resources for a period of time.” | **ECHO**

Go to Edovo on tablets for writing courses, original music, and a catalog of incarcerated writers published by Bridgeworks



art, music,
& writing

DELIVERED INSIDE & BROADCAST OUTSIDE

BRIDGEWORKS OREGON

tell friends & family to visit:

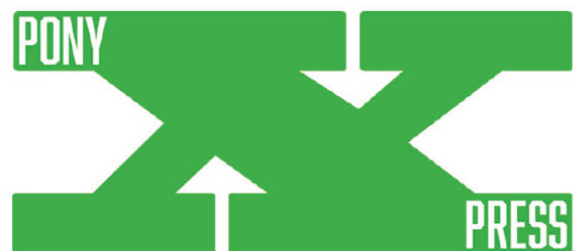

WRITING FROM OREGON PRISONS

WWW.THEPONYXPRESS.ORG

SUBSCRIBE FOR FREE

SPREADING THE WORD BUILDS AUDIENCE

UPGRADE TO PAID FUNDS THE PROGRAM

ADDING EQUIPMENT ON UNIT

Pull Up Stations to be Added to Incentive Units

Written by Kurtis Thompson



Photo by Kurtis Thompson/The Echo

A pull-up rack sits in the TV room on unit G4 in April 2026. The rack was manufactured in EOICI's welding shop and similar racks will be added to H1, H2, G3 and B1 in the future.

New workouts are available on some housing units at EOICI, thanks to the welding shop's newest build – pull-up stations.

The pull-up stations were previously proposed to and approved by the Activities Committee. The first station was built by resident welders Ernesto Casas and Doug Haggard for the call center in March. More stations are being built for incentive housing and one was recently added to G4.

“Building these was fun and a good learning opportunity,” Casas said.

The pull-up stations will be installed on incentive housing units.

Residents already have access to similar equipment during outside recreation. Workout stations, however, give residents stuck indoors more fitness options.

“Now we can do more than burpees and ride exercise bikes,” said Micah Kennedy, resident of unit G4. “It’s awesome to have something like this.” | **ECHO**

ABOUT THE LOOP

Publishers of The Loop Hope to Start a LoopGroup in Oregon Prisons

Written by Alex Dewhurst

A LoopGroup may be coming soon.

Shining Light, the publishers of a magazine called The Loop, is working to bring LoopGroups to EOICI and Coffee Creek Correctional Facility in Wilsonville.

The Loop is a magazine that features incarcerated writers and is available on Edovo and in print. LoopGroups are organized meetings where incarcerated people read the magazine and work through writing prompts.

Editor-in-chief of The Loop Kelly Beltran said “conversations are happening” to start LoopGroups in Oregon prisons.

Beltran said the groups are meant to

promote prosocial interaction and develop character strengths.

“What I’ve seen it do to my community when I was inside was a complete cultural shift,” said Matthew Hippen, who was previously incarcerated in North Dakota.

Hippen said his facility was one of the first to have LoopGroups back in 2022. He said since then the facility’s culture has changed.

“All the residents are starting their own programs, and all very supportive,” he said. “This common thread and language of character strength is woven throughout the community.”

Hippen now works as a program

specialist for Shining Light and writes the reentry article for The Loop

The Loop publishes every 10 to 12 weeks and is free upon request.

Submissions and subscription requests for The Loop go to PO Box 267, Annville, PA 17003.

Shining Light is a non-profit organization that collaborates with the VIA Institute on Character to create programming based on peer reviewed sources.

Additionally, The Loop is on the Edovo app along with more than 25 courses and other resources from Shining Light. | **ECHO**

INTERVIEWS



Photo by Phillip Luna/The Echo

The Echo interviewed acting Food Services Administrator Liza Emory this month. Formerly the Food Services Manager for EOICI, Emory is in the new role is statewide and on a six month rotation until the job is opened permanently. We talked with Emory about her goals and thoughts on food services in ODOC.

The Echo: Thanks for meeting with The Echo. What can you tell readers about your new role?

Emory: I'm just transitioning into it right now. I started on April 20 as acting food services administrator.

The Echo: What does a food services administrator do?

Emory: They oversee all of food services for the state. A food services manager oversees that at the facility level.

I'm not in charge of the managers, but I oversee the program as a whole. It is just a six-month rotation right now, but eventually they will open it permanently.

The Echo: And you'll want to con-

tinue in the role when it is permanent?

Emory: Hopefully I'll be in this role, but it will involve re-interviewing. I hope I get the job.

The Echo: What do you hope to accomplish in these six months?

Emory: There is a long list of things that I'd like to look at. But, will I be able to get all of it done in six months? Probably not.

The Echo: What's the most important thing to you?

Emory: Looking at better food sources for our population. I'm not a fan of our main protein source coming from lunch meat. We have a few raw meats, pork and chicken, that we cook and serve, but I want to see what the different options are out there. I want to look at quality. But, we also have to keep in mind the budget. We all have to be mindful of that.

Taking a look at food quality is the most important thing to me. Then, I'd like to streamline our religious service meals and look at transport meals. Yeah, there is a lot.

The Echo: You talked about budget

being a factor. Is there a correlation between health care cost and quality of food, meaning if the department spends more on food on the front end will it reduce health care costs on the back end?

Emory: That's one of things we are looking at. If we serve more nutritious food is that going to lead to a healthier lifestyle? I would imagine so, but that is going to take a lot of work, working with health services as well. That's going to be a huge project, but I think it's worth diving into.

The Echo: For mainline meals, portion sizes have shrunk in the last 10 years. Will you increase the portion sizes?

Emory: I've got to work with the dietitian to see what is feasible. It's important that we follow his standards from a health point of view.

Some things have reduced, but there are other things like, the previous dietitian wanted us to limit salad to one cup. I refused to do that and we kept salad unlimited at our facility.

There are things I want to give back to the facilities to see what they can do. I think there are some portion sizes we could look at. There are also some menu items and recipes I'd like to look at adding back.

The Echo: At EOICI we have a lot of garden space, which is uncommon in prisons. But, I've noticed we don't really grow lettuce or other leafy vegetables and winter crops in our gardens. Have you considered this?

Emory: Part of it is a space issue. But also, those crops are low yield. From an entire harvest, we might get one or two meals out of it. That's a whole growing season and only a few meals as a result.

We have had a problem with produce recently. We got a shipment of

lettuce, and a lot of it was bad when we got it. So we sent it back. It's been difficult to get good produce. That's one of the things I hope to address.

The Echo: So, if you were to have the role permanently, what would be your five-year goals?

Emory: It would be great if every institution had gardens like we have, but it's hard to say right now. I don't know what they have as far as space and ability. A big thing for me is developing teamwork between this position and the institutions. As of right now, though, it's kind of hard to say because I'm just starting my second week in this role.

The Echo: What about programs here? What is your hope for the Fine Dining Program?

Emory: I'm not sure where that is going next year. It's not off the table, but say we have someone brand new in the role as food services manager. It wouldn't be fair for them to have to carry that on, or maybe they are not ready to carry that. It's not off the table, I just don't know where it is going to be sitting yet.

The Echo: Do you want other facilities to start programs like this?

Emory: It would be cool if they did. ODOC already has a food service program. It's a pretty good program and several institutions already do it.

With the Fine Dining Program, I wanted to go above and beyond what's already being done. It gives everybody an extra opportunity, so they can go to the high-end restaurants that pay more money and have more job stability.

The Echo: What about Prison Brews? What do you hope happens with the coffee shop?

Emory: That it continues to be successful. We are getting more people trained at the job. We were very fortu-

nate that one of Pendleton's local coffee shops, Buckin' Bean, was able to come in and do training.

The Echo: Does Buckin' Bean continue to come in and do training?

Emory: No, we have guys trained up and now they pass on what they have learned.

One of our goals for Prison Brews is to deliver to the units for officers. The officer would call and place an order and then we could have someone Door-dash it to them. Coffeedash, I guess.

Eventually, we want to sell to the Level 3's in the institution.

The Echo: A lot of readers will want to know more about that. What are the chances that will happen?

Emory: I think it's really good. I think, as long as we have approval, we could do this by the end of the year. I can't see why we wouldn't have these two things by the end of the year.

The Echo: What is your motivation to work in a prison? Some people, I think, come here because it is just a job. Other people want to help incarcerated people find job skills and return to the community.

Emory: It's turned into that for me. I worked in fine dining restaurants before as an executive pastry chef. I moved back here to be around family and I couldn't find a job to save my life. A friend mentioned the prison had a food services department. I started as a coordinator.

This was a night and day difference from what you would see out in the private sector. I really began to see that there could be a heck of a lot more when I went into the bakery. The ability to teach something that a person can leave prison with and get a job almost the next day is huge. Being able to give people that skill set, that free education, it's worthwhile.

That's one of the things I appreciated about the Fine Dining Program. You are learning your knife cuts and making things from scratch, and learning all these different skills. People pay a lot of money to learn what these guys are getting for free.

The Echo: Some people, they see you as kind of a hard ass. Or maybe difficult, tough. I find this interesting, because it hasn't been my experience. What do you say to that?

Emory: Generally, like a lot of people around here, I have my blockers up. People that have worked with me a long time and see what I am doing, they are exposed to a different side.

I realize I can be a hard ass, but this isn't an easy environment for a woman to work in. I have a job to do, but on the other hand there are a lot of things here that can be very rewarding and that's what I always try to look at.

The Echo: Is there anything that people don't know about you that they would be surprised to learn? For example, I've noticed you have a lot of Star Wars memorabilia in your office.

Emory: I love Darth Vader. He is my spirit animal. Love Star Wars.

The Echo: Where does your love for Star Wars come from?

Emory: I don't know. I've always loved it since I was a kid.

Darth Vader, he's not really a bad guy. He's misunderstood. You know, he was on this nice warm planet, now he is out in space and his wife dies.

You know, maybe I'm like Darth Vader. I'm just misunderstood.

The Echo: Well, you said it. I only thought it. Is there anything I should ask you that I haven't?

Emory: In six months, there could probably be a much deeper conversation. I still have a lot to learn and figure out. |ECHO

AROUND EOCI

GREENHOUSE PREPS FOR SPRING PLANTING

Workers Hope to Reduce Costs and Bring Variety to AIC Meals

Written by Alex Dewhurst



Photo by Kurtis Thompson/The Echo

Various vegetable starts sit in the greenhouse on April 1, 2026 ready to be planted in the plots around the institution.

Adults in custody who work in EOCI's greenhouse are experimenting with ways to reduce cost and bring a variety of produce to prison meals this year.

In winter, the greenhouse nurtures plant starts for transplant to the institution's garden beds in spring. Through the growing season, greenhouse workers and volunteer harvesters will collect and deliver fresh produce to the institution's kitchen.

THE COST OF WATER

However, one problem that could slow production is the cost of water.

The greenhouse hand waters during the early months of the year until the institution turns on sprinklers in spring.

"What I've seen of the water bill, it jumps significantly [for the facility overall]," said AIC Brett Lloyd, who works in the greenhouse and facilitates

gardening classes.

According to Physical Plant Manager Greg Carlson, the water bill in January was about \$27,000. In July 2025, the bill was almost \$45,000.

Additionally, eastern Oregon experienced a mild winter which could increase the water usage.

Lloyd said he is concerned about the current budget crisis impacting the Oregon Department of Corrections. He said he wouldn't rule out the possibility of staff turning off the sprinklers to save money. He said, however, the institution makes its money back because the kitchen spends less on ingredients.

According to data gathered from the greenhouse, about 20,500 pounds of produce were provided to the kitchen in 2025, which saved the Food Services Department almost \$24,000.

Lloyd said he expects the grounds to

produce around 40,000 pounds this year, double last year's production. He said the greenhouse workers and staff are conscientious of water usage. For example, the sprinklers are scheduled in the morning to avoid evaporation during the heat of the day.

RAISED GARDEN BEDS

The greenhouse is also trying to reduce cost is with raised garden beds.

Lloyd said the greenhouse and grounds-crew workers made the raised garden beds as a response to problems they had experienced.

"The problem was that a lot of tomato plants grew into each other, so there was this mat of vegetation that they had to find the vegetables in," he said. "The raised beds keep the plants in an orderly direction."

Lloyd said the raised beds have a wide footpath between each bed to prevent the harvesting crew from stepping on the plants, which results in wasted produce.

"It also prevents soil compaction, which is bad for the plants," he said, "and it improves the drainage of the soil."

However, Lloyd said the raised beds are an experiment this year. He is unsure if they will continue because of the work it takes to make the beds.

VARIETY EXPERIMENT

Lloyd said the greenhouse will use the raised garden beds to grow more than 200 different varieties of plants.

Greenhouse worker Phillip Brown said they are growing several thousand peppers, onions, cucumbers, squash and herbs such as thyme and oregano.

Additionally, the greenhouse planted



Photo by Phillip Luna/The Echo

The raised garden beds located between E and F building sit vacant on April 28, 2026. The vegetable starts are slowly being transplanted around the various gardening plots in EOICI.

Osage corn for the institution's Native American pow-wow. Lloyd said the Osage corn was cultivated by the Osage Native Americans. He said the greenhouse planted several types of melons this year – including one which originated from India.

Lloyd said the greenhouse is experimenting with vegetables to see what grows well in the area and what people like in meals.

“A certain variety of tomato may look good on paper, but when you bite into it, it may not be all that appealing,” Lloyd said.

However, fewer zucchinis were planted compared to previous seasons. According to Brown, although zucchini increased the total pounds of crop, the vegetable was unpopular and much of it was wasted.

“Nobody wants to eat zucchini,” said Brown.

PESTS

AICs are not the only ones on the compound who might enjoy a wider variety of vegetables.

Brown said that caterpillars and moths eat a portion of the crop before it leaves the greenhouse, and gophers eat about 10% after transplant.

Lloyd said there's nothing they can do about the gophers. He said the institution is not allowed to use poison or

smoke because it could impact the local wildlife, such as osprey.

“I tell the guys to plant an extra 10% to 20% to account for the gophers,” said Lloyd.

He said the greenhouse is looking for safe alternatives to dispose of pests.

COMPOSTING AND VERMICULTURE

One animal which is not considered a pest, however, is the worm.

The greenhouse keeps worms in boxes full of soil and paper scraps as a part of their composting and vermiculture program. The worms recycle nutrients in the soil through their waste and the enriched soil is collected and spread into the garden beds.

“We get food waste from the kitchen and we incorporate it with things like sawdust from the woodshop,” said Lloyd.

He said they collect 50 to 100 gallons of compost every few months.

| ECHO



Photo by Kurtis Thompson/The Echo

Incarcerated person and greenhouse worker Phillip Brown inspects the vermiculture box located in the EOICI greenhouse on April 1, 2026.

AROUND EOCI

PEER-TAUGHT SIGN LANGUAGE CLASS

Six AICs Gather to Learn American Sign Language

Written by Chris Ainsworth



DJ Kirei/Shutterstock

Six adults in custody sat in a quiet room making hand gestures to communicate. Since 2024, EOCI has had an American Sign Language class where AICs gather and learn how to interact using American Sign Language.

“When I got here in 1999 they had no translators. They had nothing,” said Thomas Miller, a hearing-impaired AIC and class facilitator. “Before 2010, nobody knew we had deaf people at the institution.”

Miller said he began to see changes after administrative staff from the state’s capital were sent to his prison to collect data to bring facilities statewide in line with the Americans with Disabilities Act.

Nearly 15 years later, Miller began teaching ASL to a handful of AICs. The goal of the class was to make communication between themselves and their families easier. Even with the

class, students still face challenges communicating.

“Many of us struggle with staff. They will call our name or bunk and we don’t hear them,” said Steve Shelton, who has suffered with hearing loss in his right ear since childhood. “I have to explain to them that I am hard of hearing.”

Miller said some people in the institution can only communicate in writing. Currently, the ASL class is only offered to people with hearing impairment, or in one rare case to someone who’s family member suffers from a hearing impairment. For now, only one housing unit in the institution has an ADA hearing helper taking the course. A hearing helper is an on-unit work assignment that helps hearing-impaired AICs with daily tasks.

“We mostly communicate with paper. We write it down and pass it back

and forth to communicate,” Miller said. “But if you have someone on the unit that knows sign language, then that person could translate for the officer. We just don’t have that now.”

The class has two workbooks. The first addresses basics, such as the alphabet, numbers and words. The second works on combining words into sentences and reducing the number of signs to communicate efficiently. The two workbooks equate to about two years of class time.

“One of the most interesting things about ASL is the old style of signing and the new style of signing. Some signs from the old and new have different meanings,” said Shelton. “It is important to know what style someone signs with.”

When the students finish the second book, Miller will be starting a new cohort of students. He hopes the class will open up to any interested AICs. Opening the class to more people will help the hearing impaired communicate with staff and the prison population, he said. Miller expects the next class to start in September.

“I believe everybody should take it. It’s wonderful to be able to communicate with each other,” said hearing-impaired student Jose Almeida. “It’s not just beneficial for communicating with your friends or loved ones; learning ASL means you are leaving prison with a new profession.”

American Sign Language emerged in 1817. According to the National Association of the Deaf, there are between 250,000 and 500,000 fluent ASL users in the United States, including children of deaf adults. Miller hopes to increase that number every few years.

“If you are hard of hearing we will put you in the class,” Miller said.

At this time, the class is only open to people with hearing impairment. | ECHO

HAVE A BUG-FREE SUMMER

Tips for Staying Pest Free in the Summer Months

Written by Phillip Luna

With the river sitting right next to EOCI, it's no wonder spring brings a swarm of uninvited flying insects. On particularly humid days, it's best to avoid the grassy areas of the yard altogether. It is not uncommon to catch a face full — or a mouthful — of bugs. But, it turns out there are a few natural remedies that may help.

Tip one: Vitamin B can actually help prevent mosquito bites and deter bugs. Studies show mosquitoes are more likely to bite people low in vitamin B. Vitamin B is found in vegetables, eggs, pork and fish — or as a vitamin supplement.

Tip two: Baby oil on the skin will keep mosquitoes and insects from biting.

Tip three: Mint is a natural bug repellent. A do-it-yourself repellent can be made using an empty hairspray bottle, some mint mouthwash and a little bit of water.

Tip four: Avoid using deodorants, shampoos, or products that have a lot of fragrance. Sweet scent attracts bugs.

Tip five: Sweaty skin also attracts bugs. After a workout, make a stop at the outdoor shower and rinse off. |ECHO

EDOVO HAS RESOURCES FOR SUBSTANCE USE DISORDER

A Video Series, NA, AA and Substance Use Recovery

Written by Brian Daniel Bement

“My journey in recovery started with programs on the tablet while waiting for a seat in Narcotics Anonymous,” said Mickey Moore, a resident at Eastern Oregon Correctional Institution. “I’ve been going to meetings for three weeks now, and I have more than 90 days clean.”

Moore said while he was on the waiting list for NA meetings, he treated his substance use disorder with recovery material on the tablet.

According to data from the Oregon Department of Corrections, 49% of incarcerated people in Oregon have a substance use disorder.

Edovo, an information and education application found on institution tablets, provides resources for substance use disorder. Here are four resources:

Hope, Help and Humor

A video series by The Path Forward Podcast interviews addiction recovery specialists and authors.

Alcoholics Anonymous: Comes of Age

AA co-founder Bill W. talks about the program's journey from its beginning in New York and Akron, Ohio during the 1930s to its journey across the country. The publication provides personal accounts and anecdotes about the effects of the 12-step program.

Narcotics Anonymous: Reaching Out Magazine

Reaching Out is designed to help people connect to the NA program of recovery. The section “From the Inside” is filled with letters and artwork from incarcerated people who share their experience, strength and hopes to maintain a drug-free lifestyle.

Rising Strong: A Substance Use Recovery Course

This course hopes to break free those suffering from substance use disorder by teaming up with people who have been there, done that and came out stronger. |ECHO



Narcotics Anonymous meetings available

Weekly meetings

Westside morning group: 8 a.m. Mondays in D2

Westside evening group: 6 p.m. Tuesday in D2

Eastside group: 6 p.m. Thursday in D2

H unit group: 10:15 a.m. Sunday on unit



Alcoholics Anonymous meetings available

Weekly meetings

English group: Sunday at 1 p.m. in D2

Spanish group: Tuesday at 7 p.m. in D2

Send a communication form to Narcotics Anonymous or Alcoholics Anonymous to sign up.

AROUND EOCI

PEER WELLNESS PROGRAM STARTS AT EOCI

Five Incarcerated People Become Certified Peer Wellness Specialists

Written by Kurtis Thompson



Shutterstock

EOCI started a new program called Peer Wellness, where some adults in custody will support Behavioral Health Services. After 40 hours of training, five AICs became certified peer wellness specialists with the Mental Health and Addiction Certification Board of Oregon. The specialists help others deescalate emotions, make healthy choices and prevent crises.

“We’re not here to fix things or solve problems necessarily—we’re here to help people feel heard,” said Wellness Specialist William Carlson. “Sometimes that’s all a person needs to deescalate.”

William Dumas, also a wellness specialist, said, “Our job is to get people thinking about positive things and educating themselves. The more people we help change in the population, the better this whole prison situation is going to be.”

But helping other AICs is not the only benefit to having wellness specialists – they also alleviate BHS caseload pressure.

CRITICAL MASS

According to the Prison Policy Ini-

tiative, 43% of about 1 million adults in state prisons have been diagnosed with a mental health disorder. That’s about 400,000 people. To put that into perspective, Oregon’s capital, Salem, had a population of about 177,000 in 2025.

In smaller terms, EOCI has a population of about 1,350. The facility has a higher than normal number of people with a mental health disorder – about 60%, or roughly 800 people.

There are six BHS counselors at EOCI. To meet the needs of 800 people, one counselor would have to see more than six patients per weekday. Counseling appointments last about an hour, with another half hour to make chart notes. In all, counselors have about nine hours of casework to fit into an eight-hour day. This excludes group facilitation, emergency calls and other duties.

But wellness specialists can “complement and supplement the BHS program” by being more readily available than a BHS counselor, Carlson said.

If a resident is not in crisis and is

upset or needs to vent, staff can first contact a wellness specialist instead of BHS. That specialist then goes to the person and supports them. By acting as support to other AICs, wellness specialists can help without involving BHS directly. Those who are in crisis are still directed to BHS, however.

“We are the pre-crisis interventions,” said Wellness Specialist Tracy Ferguson. “And some stuff the person is going through, we’ve been through. One of our tasks is mutuality – finding things that we have in common. Then we use our commonality to learn how we’re going to overcome obstacles together.”

A wellness specialist’s work will reduce pressure on the client-laden BHS. Some residents expressed concern about BHS service shortages, but Carlson and Dumas believe the Peer Wellness program will help address those issues.

BHS Manager Brian Kubesh said the specialists will free up time for BHS counselors, possibly increasing the quality of care they provide.

BEYOND EOCI

Kubesh also said wellness specialists can use the credentials earned at EOCI to find employment after exiting prison.

In Oregon, the average annual salary for a peer wellness specialist is about \$43,000, with potential earnings up to \$54,000. In some instances, according to ZipRecruiter, more experienced specialists may earn up to \$63,000 a year.

Wellness Specialist Leonel Martinez said, “If anyone wants to take this program and help other AICs, they’re going to be doing classes again next year. I encourage anybody who feels like they can help and want to be positive to send a kyte to Kubesh and sign up.”

| ECHO



Michael Jump, 45, has been incarcerated for almost 20 years. He works in the garment factory, facilitates Narcotics Anonymous and multiple mindfulness courses. Upon release, Jump plans to work in youth outreach. The Echo interviewed Jump for this month's spotlight.

Interview by Alex Dewhurst | Photo by Phillip Luna/The Echo

Staff and adults in custody at EOCI have developed a conflict management and prevention program. In this voluntary program, AIC mentors work with AIC mentees to reduce risk before and after conflict escalates.

I would describe myself as... a larger-than-life personality. I am down to earth, but I have some grit to me. I have a big-brother, stern-uncle kind of grit. You are going to get strictly a 100% honest answer with me.

The mentors are... paving a path for mentees. Then we help them along that path.

We are people they can look up to. I would say trust is a hard one to throw around here, but this is about as good as you're going to get. It takes an AIC to say, "Hey, what are you doing?" You have to hear it from your peers.

The mentors... check in with our mentees about bi-weekly, unless we know that it's going to be more viable for the mentee to stay in the loop on a daily basis. If he needs more attention, we are probably going to meet him daily.

If I am your mentor... I am going to have you do a personal commitment for what you want. What are your aspirations and how can we apply to them?

I am going to better your systems and you are going to

feel better because of it. If you give me the time and energy and it's honest and open minded, I will try to help you any way I can. It's going to be an advantageous relationship.

I joined the mentor program when... my cellie asked me if I wanted to go after I was already facilitating mindfulness courses and NA, and I just said why not.

I became a mentor because... I am trying to open up something for a guy that is not willing to reach out, but knows that there's an avenue so when he is in crisis there is somebody in place that can help.

They look like they can lift the world, they have tattoos everywhere, they have the respectability, they have the stripes you would say – but they don't have an outlet to somebody they can relate to.

So essentially that's what drew me to it, because I've always needed somebody like that. Because if I don't look up to you then it's hard to ask you for something.

To get involved with the program... you can reach out to Lt. Booker. We can get you set up for the meetings in the chow hall.

You could also find a mentor walking around the compound with a mentee and ask for a second of their time. Jump is just one of 27 mentors available to AICs. | **ECHO**

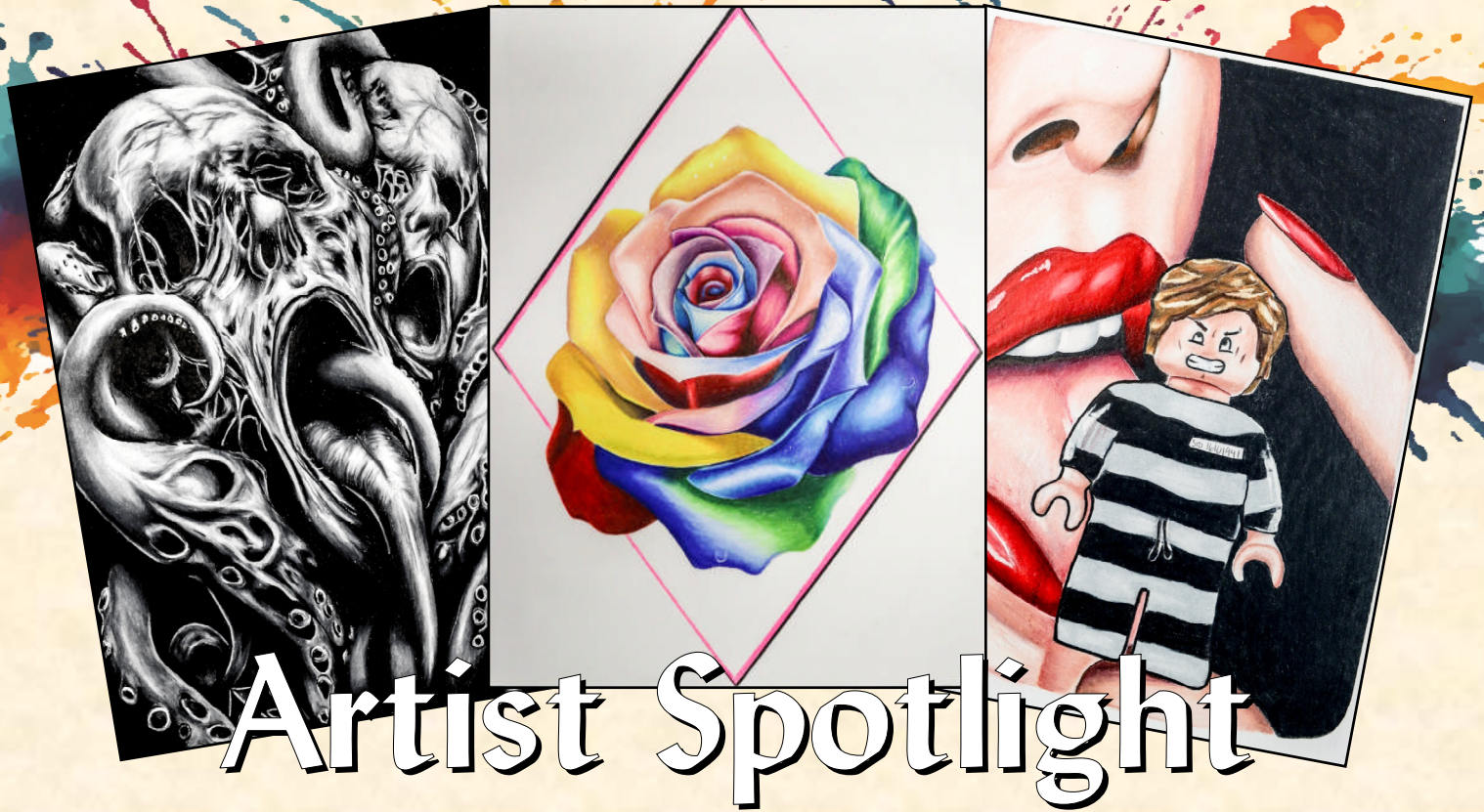

Artist Spotlight

Michael Ledbetter & Andrew Slover

Above from left to right: Screaming faces surrounded by tentacles done in black and white, art by Michael Ledbetter; a rose in multicolor, drawn by Ledbetter with coloring by Andrew Slover; a Lego man wearing an old-school prison uniform being licked, art by Ledbetter.

Below from left to right: A women drinking a slushee drink, art by Michael Ledbetter; a Native American woman wearing a wolf headdress and red eye shadow, art by Andrew Slover.

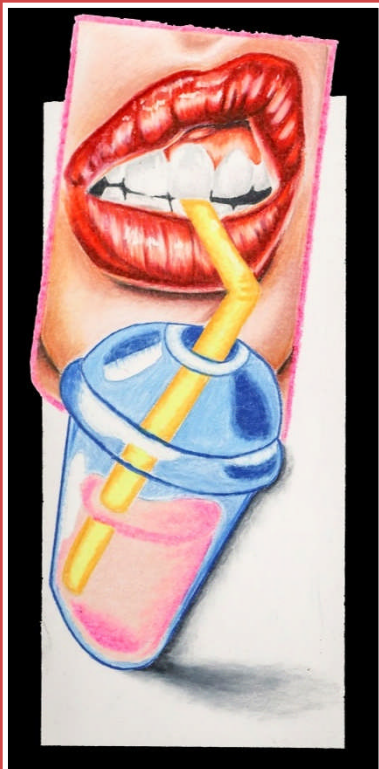

Arlie Thompson



A clipboard with a wood burning of a character from the anime and manga series Uzumaki created by Junji Ito. The kanji to the right of the woman translates to "Uzumaki" while the kanji to her left means "Potato," referring to the artists nickname "tater."

Wood burning by Arlie Thompson.

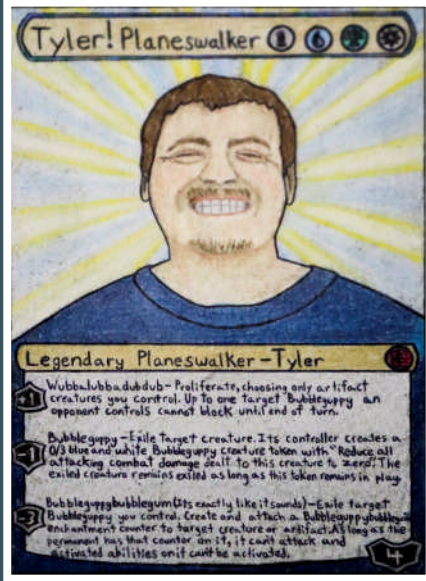
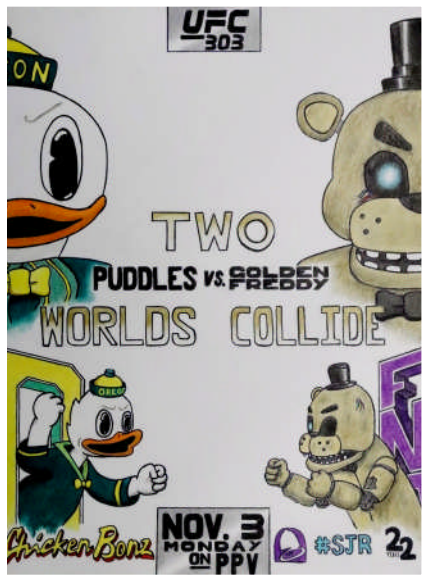

Left: A UFC fight promotion featuring University of Oregon's mascot, Puddles, and Five Nights at Freddy's, Golden Freddy. Art Jacob Stursa.

Right: A mock Magic the Gathering Planeswalker card made for Tyler Young's birthday. Art by Jacob Stursa. Card abilities created by Ian Gilderson.

Michael Ledbetter



A side profile of a female surrounded by planets and stars, showcasing exceptional use of color theory. Art by Michael Ledbetter.

Bill Williams



Top left: a platter built in the wood shop by Bill Williams. The wood-burning of a cabin next to a lake surrounded by mountains was done by Andrew Slover.



Top right: a platter built by Bill Williams with a woodburning of an elk in a forest done by Andrew Slover.



Above: A platter built by Bill Williams with a woodburning of a barn sitting on a hill. Art by Arlie Thompson.



Left: a bowl designed and built by Bill Williams.

CALLING ARTISTS

If you are an artist that would like to be featured in our artist spotlight page, contact the IWP Journalism Department.

You will be scheduled to have your artwork reviewed and photographed, along with a brief interview about the work.

VIDEO GAMES

GAMES WITH HIGH REPLAY VALUE

Including RPG, Action, Sports, Fighting and Strategy Games

Written By Logan Gimbel

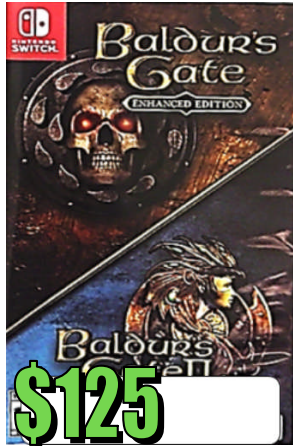

Baldur's Gate 1 and 2
Enhanced Edition
66-246 hours

The **Fully Loaded** Electronics game list has over 200 titles for gamers at EOCI to choose from. While any game can be replayed, few titles offer a different experience each play through. Some games, such as Ark: Survival Evolved, Minecraft and No Man's Sky are almost limitless, but require updates for players to fully enjoy. Here is a list of games that offer high replay value not requiring updates.

Baldur's Gate 1 and 2 Enhanced Edition is available from Fully Loaded Electronics for \$125. The game comes with expansions for each title, totaling six games on one cartridge. An average play through takes about 66 hours, 31 hours for the first title and 35 for the second. Players have multiple races, classes, party members and story options to choose from. This gives the game bundle high replay value.

Dead Cells costs \$46 from FLE and won an award for Best Action Game in 2018. An average play through takes about 15 hours, but unlocking everything takes about 90 hours. Players control a reanimated corpse and must battle through randomly generated castle and town locations in hopes of defeating the king. Each play through is different as players receive random abilities, skills and weapons.

FIFA 23: Legacy Edition costs \$80 from FLE. It includes several different modes of play, including two different career modes along with various tournaments. Playing through the career mode will take

about 126 hours while unlocking everything takes about 500 hours. This title has nearly limitless replay value as players can create and train different characters and teams to play in different tournaments. This sports game will become technical as players unlock different goal shots, pass types and other soccer skills.

Demon Slayer: The Hinokami Chronicles costs \$69 from FLE. This fighting game is based on the popular anime and manga series Demon Slayer. Gamers follow the story of Tanjiro Kamido to the Mugen Train arc, which takes about 18 hours to complete. However, this game has high replay value due to the versus mode and unlockable content. Using Kimetsu points, which can be found or earned, gamers can unlock various things such as pictures and music.

Advanced Wars 1+2 Re-Boot Camp is a new addition and costs \$69 from FLE. It is a remake of the original games which includes updated animations and a re-recorded soundtrack. A quick run of the campaign for the first and second game takes about 28 hours while playing to 100% completion takes about 90 hours. The map creator, versus mode and the option for hotseat gaming add to the overall replay value.

The above titles are only a few games with good replay value available to gamers at EOCI. Another way to judge the value of a game is for every dollar spent, the player should expect an hour of gameplay.

|ECHO



Demon Slayer: The Hinokami
Chronicles
5-18 hours

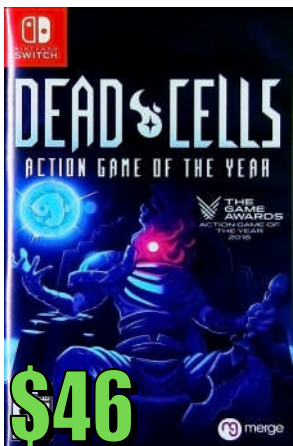

Dead Cells
15-90 hours



Advanced Wars 1+2
Re-Boot Camp
28-90 hours



FIFA 23: Legacy Edition
126-450 hours

Are there games you would like to see reviewed in The Echo?

Contact the IWP, Journalism Department or let one of our writers know.



Dmitry Demidovich/Shutterstock

A few months ago The Echo published an article about Bloodstained: Ritual of the Night in which they said a speedrun was approximately 15 hours.

I have since learned that the term “speedrun” was not the proper term, but it got me thinking: is that truly expeditious. Could I potentially do it faster?

I started a new file after learning the map and locations of everything from a previous play through. I rushed through the ship and through town to Zangetsu, missing basically every chest and breakaway wall on the way. I avoided killing any enemy except for the ones who would give me crystals and armor

I need, like the one-hand attack up from the leonine Sabnock, and the scale armor from the Grinder Knight.

I rushed through each area, only farming a few crystals to grade nine, like the Optimizer from the Ocypete enemies in the late-stage cathedral, which makes weapon attacks faster.

There was no time for any alchemy as I was on the clock, so farming had to do. I made sure to have Carabosse as a familiar so I could have the additional healing during bosses to make up for being low level.

Once I met O.D. in the library I checked out the book which upped physical attack power, beat two bosses,

checked out a second book which upped physical defense, then beat a few more bosses to check out the final book which increased attack speed.

At a certain point when starting to explore underwater, the player is forced to obtain the crystal Aqua Stream, which is free to use underwater, but even on solid ground it makes for a devastating close-range magic, so I farmed it to grade nine and in every subsequent boss battle used it until I ran out of ethers, then relied on the Ayamur farmed from the underwater horses, combined with optimizer to have fast and brutal physical attacks.

All my limited money I spent alchemizing and buying rolled omelets before fighting the boss made of gold so he couldn’t steal my funds and heal mid-battle, and rushed to the end to complete the game with a combined total of only 479 enemies killed, at level 28, in exactly 4 hours and 13 minutes and 17 seconds.

For some reason, with my specific set of books checked out, the game didn’t force the fight with O.D., so that helped cut out a lot of time, but if he could be beaten quickly, checking out all his books would make the final fight much easier.

If someone can beat this time please let me know as I enjoy the challenge. Happy gaming! |ECHO



On Edovo

The Echo and 1664 are available on Edovo. Locate either by typing the publication name into the search box.

More than 1,000 prisons in the United States have access to Edovo. In many cases, readers can access these publications and others regardless of what prison they are held in.

GAME TIPS

Do you have video game tips or challenges you would like to share with our readers? Let us know!

Contact IWP, Journalism Department via communication form (kyte). We will schedule someone to meet with you.

COMMUNITY VOICES

RUNNING IN CIRCLES

How Running Programs Help People Cope with Long Prison Sentences

Written by Brian Daniel Bement



Photo by Phillip Luna/Stock image, The Echo

“Let me tell you the way it was, in those days everyone in that running program were the healthiest they had ever been in their life,” said Jake Reynolds, reminiscing about the Oregon State Penitentiary running program in 1982. “Running is the healthiest way to change your life.”

It was a warm, breezy afternoon in March 2026. Reynolds, 75, had spent 46 years in prison, and Fredrick Turner, 68, left prison after 42 years and came back on a parole violation. The two men sat on a bench at their eastern Oregon prison talking about the old days.

Reynolds thumbed through photos from the running program at OSP in the ‘80s. In the photos were incarcerated men in short-cut, green shorts, sometimes with great big smiles as

they ran around an asphalt track that was hazy from the heat of summer. There was a snapshot of an award ceremony, with six people holding up golden trophies—winners of a race.

“We ran and trained together every day,” said Reynolds.

The running program gave incarcerated people a family and reason to work out, he said. In those days, prisons had less rehabilitation programs than today, he added.

Reynolds left OSP in 2003. The Echo was unable to confirm if a running club still exists at the facility.

RESURGENCE OF RUNNING

Prison running programs were uncommon in the 1980s, but dozens have sprouted up in recent years, thanks in part to San Quentin Rehabilitation Cen-

ter in California.

In 2023, the award-winning documentary film “26.2 to Life” highlighted San Quentin’s 1,000-Mile Club marathon, named because a marathon is 26.2 miles. The film featured incarcerated people training and running a marathon behind prison walls.

The documentary sparked seven new running programs inside adult and juvenile facilities; programs started in Ohio, Colorado, California and Washington State.

At Washington State Prison, the Concrete Conquerors Runners Club created a separate yard for runners. The club focuses on safety, mental and physical health for its members.

Eastern Oregon Correctional Institution, where Reynolds and Turner currently reside, has never had a running program. The facility did have a runners yard in the early 2000’s, however, it was closed due to lack of interest.

Reynolds said he was disappointed when the runners yard ended.

He said running is a “game changer” when it comes to mental health.

Turner expressed a similar sentiment, and said his mental health was poor the first time he came to prison in 1977. Running was how he coped with his time.

Compared to a runners yard, which

is a designated time for runners to use the track, a running program involves peer support and structured races.

“A running program is a mentorship program that focuses on inspiring people to solve their issues through physical fitness,” said Turner. “Most of the people I know talk about their issues while working out.”

Running programs help people to become resilient and focus on their next goal, he said.

THE NEXT GENERATION

Jacob Nebeker, another incarcerated person at EOIC, likes to run. At age 30, Nebeker is five years into a life sentence and said running helps him cope with depression.

A study by the U.S. Department of Health and Human Services showed regular physical activity improves mental health. Exercise can prevent or alleviate depression.

But Nebeker said there are challenges at EOIC. The track is small and full of people, making it hard to run without an accident.

The track has four narrow lanes marked by uneven painted lines which stretch one-fifth of a mile. The weathered asphalt is wavy from potholes, like an inner-city road under repair. From a distance, the track’s sharp corners make more of a rectangle than oval. The shape, some runners say, puts painful pressure on their knees, but the real hazard is walkers.

Nebeker said people walking are inattentive to the runners. Every hundred feet, there is almost a collision. Ultimately, a running program, with sanctioned races and running times, would be ideal. But, he said he hopes the prison at least opens a runners-only yard again.

Two decades ago, EOIC’s runners

yard was open in the early morning hours, around 6 a.m.

That being said, the facility recently extended morning yard hours by 30 minutes and added an extra yard line to the afternoons.

ALL ABOUT HEALTH

The Department of Health and Human Services recommends running 75 minutes a week to reduce the symptoms of depression and anxiety while promoting cardiovascular and respiratory health. While running initially spikes a stress response in the body, people have lower levels of stress hormones over time. Their study shows improvements to mental and physical health in as early as two weeks.

“You got to stay healthy in life, especially if you aren’t getting out of prison soon,” said Turner, expressing his thoughts about running in the 1980’s.

Reynolds said he would volunteer to help a running program, if one started at his facility. But for him, running is more difficult at 70. It would take too much time to get in shape to run, he said. But, Reynolds believes Turner, who is a few years younger, still has it in him to win races.

Upon hearing this, Turner stared off into the distance as if contemplating his future victories in a running program.

“When I discovered running, it was medicine,” he said. “Serving a life sentence is a tough pill to swallow.”

Turner said running saved his life.

Prison running programs embody camaraderie, community, resilience and rehabilitation. Through the challenge of learning to run and train for a marathon while incarcerated, people foster personal growth in a positive environment. | ECHO

BASIC CHEESECAKE RECIPE

Provided by Rodney Rodriguez

Ingredients and tools:

- 3 bowls with lids
- 1 protein scoop
- 1 spoon
- 7 cream cheeses
- 1 bag of powdered milk
- 1 scoop of vanilla creamer
- 1 vanilla cookies

Step one: Open the rack of vanilla cookies and put half into one bowl. Then start scraping the filling out of the second half of cookies and save it in the wrapper. Put the cleaned cookies in the second bowl.

Then, scrape the first cookies too, but keep them in separate bowls. Now crush the cookies to a powder. They should be at least smaller than a piece of rice. Then put them back into one bowl. Now with the scoop, fill it three-fourths of the way full of water and add it to the cookies and stir until all the water is gone.

Then start smashing it into a dough ball. After it’s worked into a ball, cut it in half and line the bottom of the two bowls and cover with lids for now.

Step two: In the third bowl, add the fillings and all the cream cheeses plus one scoop of vanilla creamer. Stir until most of the chunks are gone. Then add three protein scoops of milk powder and stir until smooth. Continue to add one protein scoop at a time and mix smooth until all the powdered milk is gone.

Step three: Divide the filling evenly over the two crusts, cover to let it set up for about six hours. Then put toppings on and ice it for a couple more hours.

| ECHO

NEWS BRIEFS

NEWS BRIEFS

The Obituary of a Legal Tote

—The Echo

In the issue 89 of The Echo we published a recipe submitted by Rodney Rodriguez for caramel popcorn balls. The recipe called to use a legal tote for ease of mixing, which EOIC administrators said is the incorrect use of a legal tote.

Please keep in mind, The Echo is not a permission slip for anything. As best practice, talk to your unit officer. Asking beforehand is the quickest way to prevent most problems.

Time-Served Credit Calculation Under ORS 137.370(4)

— Offender Information and Sentence Computation Unit

The Oregon Supreme Court's decision in *Torres-Lopez v. Fahrion* has significantly changed how the Oregon Department of Corrections (ODOC) calculates Time Served Credit (TSC) under Oregon Revised Statute (ORS) 137.370(4).

In July 2025, the Offender Information and Sentence Computation (OISC) unit began reviewing sentences imposed on or after August 1, 2015, to determine potential impacts from *Torres-Lopez v. Fahrion*. OISC worked closely with the Oregon Department of Justice (DOJ) to refine and establish DOC's policies regarding TSC calculations, ensuring they align with the Court's intent.

Key Points About This Review

Prioritization: Reviews will be prioritized based on projected release dates.

Eligibility: Only sentences imposed on or after August 1, 2015, will be reviewed.

Re-Review: Sentences reviewed under former TSC policies will be re-reviewed to ensure compliance with current policies.

Notification: If an Adult in Custody (AIC)'s projected release date changes, the AIC will be notified through written communication delivered via institutional mail to the AIC's housing unit. The notice will include:

- Updated projected release date
- An explanation of the change

Questions?

AICs may submit an AIC Communication Form (CD214) to their Prison Term Analyst (PTA). The PTA can provide a detailed breakdown of the sentence calculation, explain the application of TSC, and address any other questions related to the sentence.

- If an AIC believes they are entitled to additional TSC under ORS 137.370(4) or that their calculation is incorrect, options include:
- Working with legal counsel to obtain a corrected judgment
- Consult with a Legal Assistant in the facility's Legal Library
- Write to the sentencing court for the affected case(s)

Due to the volume and complexity of reviews, this process will take time, and not all reviews will result in a change to projected release dates.

Cálculo de crédito por tiempo cumplido según ORS 137.370 (4)

—Unidad de Información del Ofensor y Cómputo de Sentencias

La decisión de la Corte Suprema de Oregon en *Torres-Lopez v. Fahrion* ha cambiado de manera importante cómo el Departamento de Correcciones de Ore-

gon (ODOC) calcula el crédito por tiempo cumplido (TSC) bajo la ley ORS 137.370(4).

En julio de 2025, la Unidad de Información del Ofensor y Cómputo de Sentencias (OISC) comenzó a revisar las sentencias impuestas a partir del 1 de agosto de 2015 para ver cómo podrían verse afectadas por este caso. OISC trabajó de cerca con el Departamento de Justicia de Oregon (DOJ) para ajustar y establecer las políticas del DOC sobre el cálculo del TSC, asegurando que estén alineadas con la intención de la Corte.

Puntos clave sobre esta revisión:

Prioridad: Las revisiones se harán primero según las fechas proyectadas de liberación.

Elegibilidad: Solo se revisarán sentencias impuestas a partir del 1 de agosto de 2015.

Revisión nuevamente: Las sentencias que ya se revisaron bajo políticas anteriores de TSC se volverán a revisar para asegurar que cumplan con las políticas actuales.

Notificación: Si cambia la fecha proyectada de liberación de una persona bajo custodia (AIC), se le notificará por escrito a través del correo institucional en su unidad de vivienda. El aviso incluirá:

- La nueva fecha proyectada de liberación
- Una explicación del cambio

¿Tienes preguntas sobre el cálculo de tu sentencia?

Puedes enviar un formulario de comunicación de AIC (CD214) a tu Analista de Término de Prisión (PTA). El PTA puede darte un desglose detallado del cálculo de tu sentencia, explicarte cómo se aplicó el TSC y responder a otras preguntas relacionadas.

- Si crees que te corresponde más crédito por tiempo cumplido o bajo ORS 137.370(4) o que

tucálculo es incorrecto, puedes:

- Trabajar con un abogado para obtener una sentencia corregida
- Consultar con un asistente legal en la biblioteca legal de la institución
- Escribir a la corte que emitió la sentencia

Debido al volumen y la complejidad de estas revisiones, este proceso tomará tiempo, y no todos los casos resultarán en cambios en la fecha proyectada de liberación.

Magazines and Book Reviews by Mailrooms

— Notice from Bryan Stephen, Chief of Security, ODOC

Books and magazines that come through ODOC's mailrooms are each reviewed individually to determine if they meet the standards set forth in ODOC's mail rule, which can be found at OAR Chapter 291, Division 131 "MAIL (AIC)".

Under OAR 291-131-0037 8(b), "Vendors that repeatedly send prohibited content to adults in custody after multiple violation notices informing them of mail rule standards may be restricted."

Currently, there are no magazine vendors prohibited based on this criterion. What this means is you can subscribe to any magazine you'd like, but each issue of the magazine will be reviewed as it arrives at the facility. If mailroom staff determine that a specific magazine issue violates the rule, it is marked in the system as "provisionally rejected" with the suspected violation noted for review by the mail rule central administrator. When magazine issues or books are provisionally rejected, they are held at each facility mailroom until the next

steps of the review are taken. The central administrator will then either confirm the rejection or will disagree and the magazine issue will not be rejected. This is why a magazine issue may be ok one month, then the next issue rejected the next month.

There is an appeal process for these magazine issues or books that are provisionally rejected by the mailroom staff and confirmed for rejection by the central administrator. As written in the CD618A "Mail Violation Notice" the appeal is sent to the Functional Unit Manager at the facility where the violation notice was written. This is the Superintendent at the facility, who likely has a designee responsible for mail. The Functional Unit Manager has the latitude to review the material and determine if they want to allow a magazine issue or book that violates the rule into the facility they are responsible for.

ODOC recently made changes to the mail rule to help mitigate the smuggling of drugs into facilities. The rules regarding pictorial or written content did not change, they are the same.

Note: Magazines change over time. Every new editor may result in differences in the magazine content. When attempts are made to "find the line" of what's ok and what's not, when boundaries are pushed to find where that line is, eventually the line is crossed. There are some magazines which previously had content that did not cross the line, but lately they have pushed across the line with what they write or the pictures they print. When that happens, more individual issues of that magazine end up being rejected. People may assume the entire magazine publication is banned when it is not.

As a customer or potential customer of a magazine, you must determine if you want to spend money on magazines that seem to be rejected regularly.

PREA INFORMATION

Sexual abuse and harassment are never okay. Tell Someone. GET HELP.

Call the Inspector General's Hotline:

1. Pick up a handset
2. Press *999 to leave a message

All PREA Calls are confidential.

Send a letter to the Governor:

Governor's Office, State Capitol, Room 160, 900 Court St., Salem, OR 97301

The Oregon Department of Corrections has a zero-tolerance policy for sexual abuse and harassment. AICs' family can report on their behalf by contacting the Inspector General's public hotline at: (877) 678-4222.

El Abuso sexual y el acoso sexual nunca son aceptables. Avisele a alguien. CONSIGA AYUDA.

Llame al Inspector General:

1. Al numero de ayuda:
2. Levante el teléfono, marque *999.

Todas las llamadas a 'PREA' son gratis y confidenciales.

También puede reportar a la oficina del Gobernador por escrito.

Governor's Office, State Capitol, Room 160, 900 Court St., Salem, OR 97301

Sus amigos o familiares pueden hacer un reporte llamando a la línea del Inspector General al 877-678-4222.

PREA Advocate:

You may write the PREA advocate at:
ODOC PREA Advocate
3601 State St.,
Salem, OR 97301

NEWS BRIEFS

NEWS BRIEFS

— From the *Administrative Rules Program*

Below is the list of status changes made to DOC administrative rules since 3/31/2026.

PROPOSED RULES:

291-037 Request for Public Record

- Amends rule to establish a process to collect credit card payments from individuals requesting public record.

Comment Period: Comments must be received by the Rules Office before 12:00PM (noon) on 6/17/2026.

PERMANENT RULES:

291-041 Searches (Institutions)

- Amends rule to authorize and establish the department's policy and procedures for the implementation and use of electronic searches (body scanners) in Department of Corrections facilities for the searching of adults in custody.

Effective: 5/1/26

291-076 Suicide Prevention in Correctional Facilities

- Amends rule to replace "inmate" with the statutorily required term "adult in custody"; use person-first, gender-neutral, and community-accepted language and standard department definitions and terminology; clarify the rules or processes; and update processes.
- OAR 291-076-0040 is under temporary adoption effective: 3/31/2026 through 9/26/2026

Effective: 4/24/26

291-139 Legal Affairs (AIC)

- Amends rule to 1) allow the Legal Library to make copies of letters addressed to the Attorney General and the District Attorney, and 2) allow adults in custody to access secure network storage.



In partnership with **CURE**, the **Oregon Department of Corrections Reentry and Release Unit** invite friends and family of individuals nearing release to learn about the release process, support services and timelines.

To join an upcoming online Reentry and Release Community Outreach Session, please use the QR code to access the Microsoft Teams link.



Oregon CURE's mission is to reduce crime by advocating for effective criminal justice policies and practices.

We are a volunteer organization for families and friends of those in prison.

Effective: 5/1/26

291-158 Trust Accounts

- Amends rule to change the term "inmate" to "AIC"; align the rules with current practices or with statutory definitions; codify current practice; clarify; update definitions or statutory references; establish guidelines for the assessment of fees to establish a trust account in accordance with ORS 421.125(2) (f); and clarify the AIC's responsibility associated with stop payment requests.

Effective: 5/1/26

Letters to the Editor

The Echo publishes letters to the editor on occasion. If you have a questions, comment or something you would like to share, send a communication form to IWP, Journalism Department and let us know.



Letters to The Editor

Edited for length and clarity

To The Echo,

With the weather getting warmer I have a questions. What are the distances around the tracks on the East and West yards? How many laps does it take to walk a mile?

— Warm Weather Runner

Hello Warm Weather,

What an odd questions to ask a journalism department.

As it is, we happen to know five laps on either track is a little more than one mile. For example, if you run on the inner most lane on the east yard's track, five laps equals about 45 feet more than one mile (a mile is 5,280 feet). To put that into perspective, 45 feet is 15 yards, or about half the outdoor basketball court.

The west yard's track is slightly longer than the east.

— The Echo

Dear Eastern Oregon Correctional Institution newsletter,

I am writing you to ask if you can please send me any art or drawing or coloring books. I am an artist and I

love to draw, but right not I could really use some new ideas. I'll draw something custom and send it back to you.

— Jason from a facility in Oroville, California

Hello Oroville,

Unfortunately, that is not something we do. We don't have art templates. Occasionally we publish artist spotlights (pages 20-21). If you would like to send us your artwork, we can certainly consider using it in the next spotlight. But, please keep in mind we would be unable to mail it back to you.

We hope you keep reading The Echo.

— The Echo

To The Echo,

We haven't you guys written anything about Jacob Harper?

— Concerned

Hello Concerned,

At this time, administrators at EOCI have determined their publications should not publish obituaries. This is a recent change. We understand this may be confusing, since we have previously

published obituaries.

We can tell you that the chaplains submitted a proposal for twice-yearly memorial services. We will provide them with photos and the information we have for the three people who have passed away this year. Additionally, multi runs an obituaries on their institution channel.

— The Echo

To Echo publishers,

Here is an article idea.

"Land of the Giants" starring Lil Phil of G4. Get pictures of the games he is in, going against tall players, the feisty, agile good-hearted man he is.

— Chris Johns, multi ref

Hello Chris,

Thanks for the idea. We actually wrote a story a few years ago about underdogs in basketball. We had some vertically challenged players going up against a few tall guys. But this is always good subject matter (everyone loves an underdog story). We'll let this idea marinate and see where it goes. Thanks!

— The Echo

PUZZLES

See how many points you can score in one word!

Scrabble Board: May 2026

Scrabble Basic Rules

No proper nouns like names or places

No contractions like "it's" or "that's"

No abbreviations like "app" or "spec"

Board Scores

TW = Triple Word Score

DW = Double Word Score

TL = Triple Letter Score

DL = Double Letter Score

TW			DL					TW				DL			TW
	DW				TL				TL					DW	
		DW				DL		DL					DW		
DL	T ¹	I ¹	N ¹	T ¹				DL				DW			DL
				I ¹								DW			
	TL			G ²	TL				TL					TL	
		DL		H ⁴		DL		DL					DL		
TW	S ¹	E ¹	C ³	T ¹	I ¹	O ¹	N ¹					Q ¹⁰			TW
		D ¹				DL	O ¹	B ³	S ¹	C ³	U ¹	R ¹	E ¹		
	TL	G ²			TL					TL		A ¹		TL	
		E ¹			DW						DW	S			
DL			DW				DL					A ¹			DL
		DW				DL		DL				R ¹	DW		
	DW				TL				TL					DW	
TW			DL					TW				DL			TW

PLAYER 1

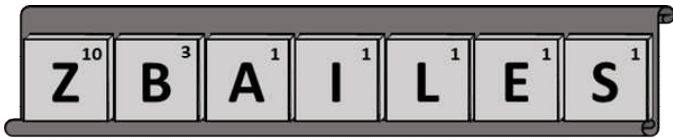

PLAYER 2

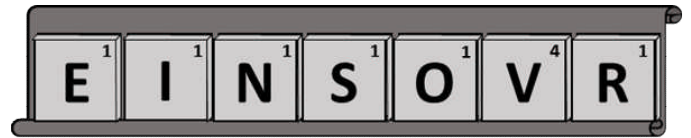

The Big Book of Mind-Bending Puzzles By Terry Stickels

The diagram below can be drawn without lifting your pencil or crossing any other line. Can you do it?

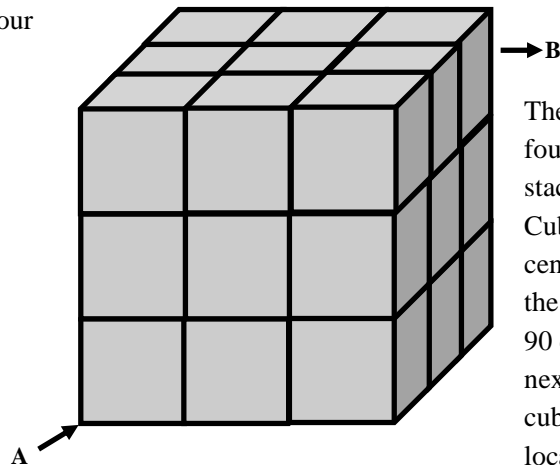
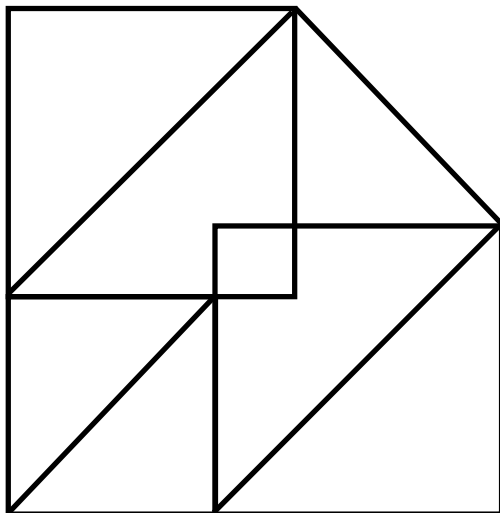

The dreaded cube-eaters from the fourth dimension descent upon a stack on 27 identical sugar cubes. Cube-eaters can only eat to the center of a cube. When they reach the center, they always make a 90 degree turn and proceed to the next cube. They never reenter a cube. If a cube-eater enters at location A, what is the minimum number of cubes it will eat through to reach the cube at location B?

CROSSWORD PUZZLE

Theme: Picnic in the Park

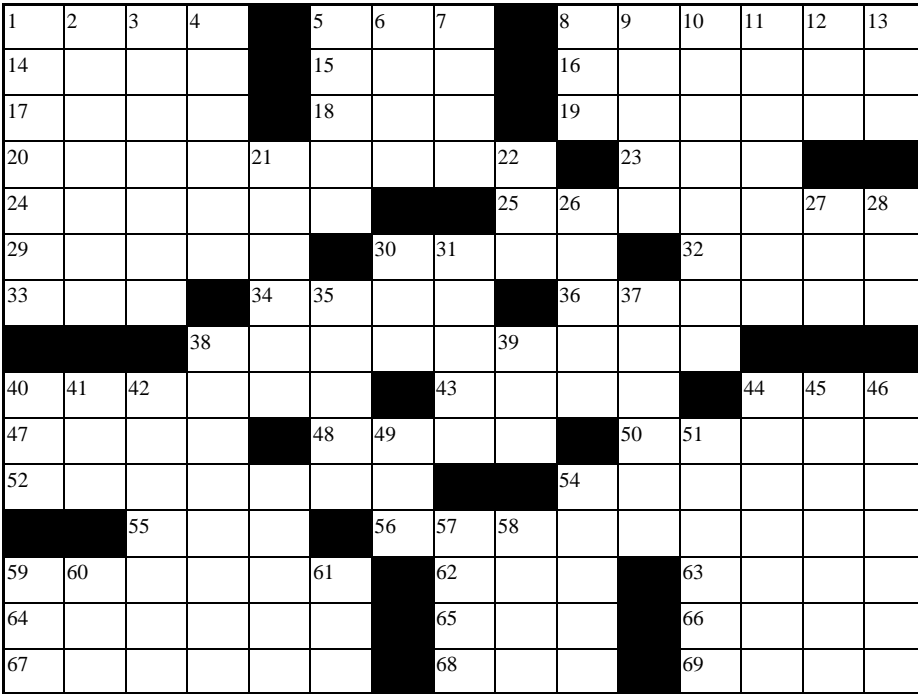

From USAtoday.com

Puzzle created by Diane C. Baldwin

DOWN CONT.

- 39 Conciliatory offering
- 40 CD follower
- 41 Start for center or tome
- 42 Thinks back on
- 44 Scam artist
- 45 Crew member
- 46 Settings for pearls
- 49 Common ID
- 51 Write down
- 53 Lyric poem
- 54 Testatrix or aviatrix, e.g.
- 57 Solmen promise
- 58 Certain Manitoba Indian
- 59 Curtail one's freedom or speech
- 60 Carte words
- 61 Kennedy in Congress

ACROSS

- 1 Place for la familia
- 5 Cries of delight
- 8 Reach the op
- 14 Constantly
- 15 First name in bombshells
- 16 "Twelfth Night" character
- 17 Kind of cod
- 18 School of thought
- 19 Bad place to be hanging
- 20 "Nothing to it!"
- 23 Slalom trail, perhaps
- 24 Moonshiners' devices
- 25 Legumes used in soup
- 29 Sculpted, as muscles
- 30 Monogamy quorum
- 32 Eye feature
- 33 Unit of force
- 34 Casting requirement
- 36 Overrun, in a troublesome way
- 38 Toss out
- 40 You may have seen them before
- 43 Large number
- 44 Egg ___yong
- 47 Grp. with crude intentions?
- 48 Stat equivalent
- 50 Do Parquetry
- 52 Rooney and Spillane
- 54 Matrimonial hopefuls
- 55 Egyptian viper
- 56 A romp
- 59 Awkward fellow

- 38 A breeze
- 63 High point
- 64 Hint at
- 65 Kind of party
- 66 Go at a gallop
- 67 Showed one's shock
- 68 Mother ptarmigan
- 69 Sea eagles

DOWN

- 1 First name is the "All About Eve" cast
- 2 Flyboy
- 3 Somehow being aware of
- 4 Fancy sock
- 5 Off target
- 6 Barn door hardware
- 7 Trucker's rig
- 8 Addressee of many requests
- 9 Extraterrestrial
- 10 Child's play
- 11 Deliberately vague
- 12 Sundial number
- 13 Old salt
- 21 U.S. astronaut Buzz
- 22 Yalie
- 26 Some native New Yorkers
- 27 "___ Miserables"
- 28 Was left idle
- 30 Vitality
- 31 Tower in Honolulu
- 35 Literary composition
- 37 Fanciful idea
- 38 A breeze

ANSWER KEYS

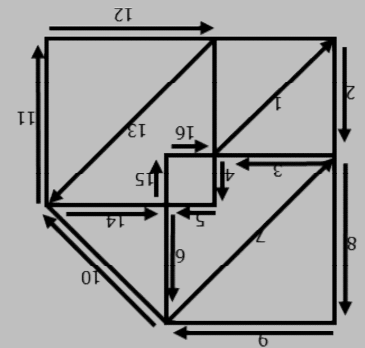
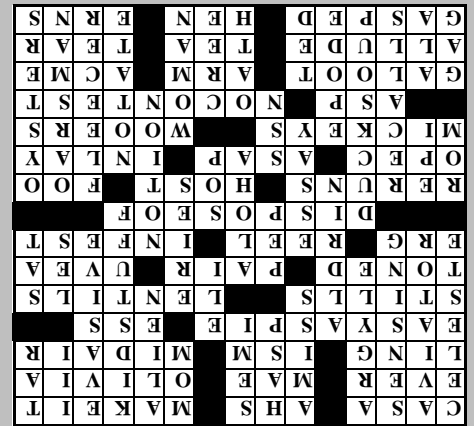

Seven



The Stillwater Awards

for excellence in prison journalism

*From the editorial team of the
EOCI Journalism Department*

In April, EOIC's Journalism Department competed in the Stillwater Awards against more than 300 entries across the United States. We took home three prizes during the ceremony, including third place in Best Magazine for 1664.

Our journalism team, as well as advisor Berit Thorson and administrative staff from the facility, gathered on April 28 to watch the award ceremony via video.

"We are only a handful of incarcerated people in Oregon allowed to do what we do," said Alex Dewhurst, the newest writer in the department. "I am so thankful for the trust that staff has in our integrity."

The event allowed for hundreds of people to watch live as the awards were presented. For many of us, our families and friends were able to tune in.

"I buzz with excitement each day I come to work because I know what I do really matters," said Dewhurst.

Since 2025, our EOIC Journalism Department has won four Stillwater Awards, five American Penal Press Awards and one award from the Oregon Department of Corrections for Outstanding Service.

Our publications, The Echo and 1664, are created by incarcerated people — from the writing, editing, and photos to the design and layout. But the work would be impossible without the efforts of administrators at our facility and beyond.

For many stories, staff members are the source of our information, providing interviews, resources or setting us up to write these stories. They have even created processes for reporting to happen in the prison setting. Without staff support, these publications would not exist.

"Our staff take time from their lives to make this program successful," said Brian Daniel Bement, a writer with The Echo. "I'm honored to be a part of this program. It means a lot to me and other incarcerated people to be able to express ourselves."

"I'm fortunate to be in this program," said Logan Gimbel, design and layout for The Echo. "We're learning skills applicable to the real world."

Additionally, our publications are sponsored by Pollen Initiative, a non-profit dedicated to cultivating media centers inside prisons to shed light on the justice system. Pollen has shined an incredible spotlight on our publications and we would not have the success we have had without their support.

In addition to our two prison publications, the Journalism Department publishes writing outside of prison. We work with and publish articles with newspapers and online publications.

The Stillwater Awards honors writing from incarcerated people that is mainly published outside of prison.

This year, Phillip Luna, editor-in-chief of The Echo and 1664, earned first place for Best Reported Essay and third place for Journalist of the Year for his work in journalism published outside the prison setting. Luna is also a senior reporter for the Prison Journalism Project, a non-profit that focuses on prison journalism.

Luna was one of four writers with PJP that was honored at the Stillwater Awards. On the following page is a story published by PJP highlighting their award-winning writers.





PJP WRITERS AND THEIR AWARD-WINNING STORIES ABOUT LIFE BEHIND BARS

The Stillwater Awards, Announced in April, Celebrate Journalism that Chronicles the Full Complexity of People

Published by the [Prison Journalism Project](#), reprinted with permission

For the third year, the Society of Professional Journalists and Prison Journalism Project have hosted the Stillwater Awards, an annual contest dedicated to honoring journalists behind bars whose lived-experience reporting sheds light on the U.S. prison system.

This year, PJP celebrates several standout contributors, including Phillip Luna, who earned the third-place spot for Prison Journalist of the Year, while also securing first place for Best Reported Essay.

He is joined by Derek Carter, who took home second place in the reported category for his story on mental health crises in prison; Kelsey Dodson, who earned third place for her poignant essay on menstruation behind bars; and Patrick Irving, whose story on caring for the elderly in prison earned him the third place spot for Best Op-ed. (PJP does not participate in judging the Stillwater Awards submissions).

We asked this year's winners to discuss the inspiration behind their stories and the determination required to practice journalism in prison. Here is what they had to say about their road to the Stillwater Awards.

INTERVIEW WITH PHILLIP LUNA

[The Night I Ate Wagyu Steak in Prison](#)

“When I bit into the wagyu steak, it reminded me of the prison sentence I’m serving. It reminded me of dropping out of college. It reminded me of

my selfishness. It reminded me that back when it mattered most, I didn’t take advantage of my privileged position. Eating wagyu steak made me feel regret.”

Q: What drew you to this story? Was there a moment when you thought, “I have to write about this”?

Phillip: I think the food drew me in, if I’m honest. The event itself was newsworthy because it showcased a high-cuisine culinary program that was unlike any other prison program in the United States [that I know of]. But once I was there, it made me reflect on life and my relationship with my father, who was a butcher by trade. I was on the phone with him sometime after the event when I knew I had to write this. My personal experience and the guilt I felt allowed me to add some pathos to the article. Without my experience, the story is still newsworthy, but adding my experience makes the article well-rounded.

Q: Has the process of reporting on your surroundings changed how you live your daily life in prison?

Phillip: I view journalism as a historical record; prisons are hidden places, with very little historical record. I cannot think of a more important role in prison than that of a reporter, to try and give a voice to people who are marginalized, warehoused and often forgotten.

What I knew about prison before I came here, in 2015, was very different from what I experienced. What I saw in movies and the media is a sensational-

ized version of prison and the people that live here. I often compare it to reading about a car crash in a newspaper. A person outside of prison might read about a car crash, maybe a significant one, in their local newspaper. But they also drive a car, probably daily. What they see on the road is cars not crashing. So, they have a lived experience that tells them the car crash they read about is unusual or rare. Most people don’t have lived experience in the prison system. When they read about a riot, violence or abusive guards, they assume that’s all the carceral system is — car crashes — all the time.

But I have seen incredible acts of compassion and perseverance in prison, from incarcerated people and prison staff. I have also seen guilt, regret and accountability. It’s not that the stories that make the mainstream media are untrue. Terrible things happen in prison. It’s just an incomplete picture. I feel that the reporting I do helps complete the picture of what it means to be incarcerated.

Q: Can you describe the journey of this story from draft to publication? Did you learn anything about yourself as a writer or journalist along the way?

Phillip: I spent three days prior to the event following the students of the culinary program around the bakery, kitchen and in their class. I watched, interviewed and photographed them as they prepared for the event. I researched the French names

(continued on next page...)

AWARD WINNERS

of food they were cooking to make sure I had it right and interviewed people attending the event and prison administrators after the event. And, of course, I attended. I tried to really immerse myself. I put a lot of hours in.

I wrote a draft and was really proud of it. I had a lot of quotes and interviews going in, so I was set up nicely. Of course, my draft wasn't perfect and there were still some rewrites and edits from PJP editors. But I think this was one of the strongest starts to an article I've had. One of the first articles I wrote for PJP took 10 months of edits and rewrites [PJP editor's note: That [story](#), about a former white supremacist, placed second in the category of Best Feature in the 2025 Stillwater Awards.] This one was pretty quick, in a few weeks. It felt like growth.

— PJP Editors

INTERVIEW WITH PATRICK IRVING

[Who Should Care for the Elderly in Prison?](#)

"Kelly was a 69-year-old, partially paralyzed amputee when he was wheeled into my prison cell with his oxygen machine in tow. ... A stroke in 1999 left his left arm paralyzed. Aggressive diabetes took the leg below at the thigh. I am not a nurse. My cell at the Idaho State Correctional Institution is the size of a compact parking space. That I was convicted on two counts of arson doesn't quite qualify me to act as a caretaker. Nonetheless, I soon became Kelly's."

Q: What drew you to this story? Was there a moment when you thought, "I have to write about this"?

Patrick: At the time, I felt writing on this subject was the only choice I had. Policy dictated that prisoners who

refuse housing assignments be issued disciplinary infractions and placed in solitary confinement. Writing was the best thing I could do to embrace and bring purpose to the situation.

Q: Has the process of reporting on your surroundings changed how you live your daily life in prison?

Patrick: For me, no. As for Kelly, his other leg was amputated just before this op-ed was published. It took him becoming a double-amputee stroke victim to be relocated to our prison's long-term care unit, where he's now offered more immediate support. My work as a peer-mentor allows me to visit him.

Q: Can you describe the journey of this story from draft to publication? Did you learn anything about yourself as a writer or journalist along the way?

Patrick: This story stemmed from a report of elder abuse that I initiated on Kelly's behalf. I gave the report some legs by posting it to my blog and directing traffic to it, which caught the attention of PJP Editorial Director Mason Bryan. After Mason asked about my interest in converting the report into an op-ed, I was paired up with Romaisaa Benzizoune, a contract editor for PJP. Romaisaa worked with me through several drafts until the piece was ready to publish.

Some months after it ran, I raised enough money from my fellow prisoners to mail out over 100 copies of it — along with a personal essay I wrote on the value of mentors in prison — to Idaho lawmakers, media and others. It's been difficult to gauge the impact of this effort because we received so little feedback.

One thing I learned through this process is to keep faith in the things that compel me to speak out on behalf of others.

INTERVIEW WITH KELSEY DODSON

[What It's Like to Have Your Period in Prison](#)

"In an environment where nothing is private, even the most basic aspects of personal care become luxuries. For incarcerated women, managing a menstrual cycle is not just a routine part of life — it is often a monumental struggle."

Q: What drew you to this story? Was there a moment when you thought, "I have to write about this"?

Kelsey: Why we have white panties has been something that I have wondered about for my entire incarceration. It makes you feel ashamed, especially in an open living environment. Subpar sanitary products, limited cleaning options and white panties is a recipe for disaster.

Q: Has the process of reporting on your surroundings changed how you live your daily life in prison?

Kelsey: Writing this article has expanded my abilities to see beyond what I perceive as normal and see it through the lens of someone who has never experienced prison. Here, it is easy to adapt to the abnormal and sometimes shocking way in which we must live. You just do what you have to do in order to survive.

Q: Can you describe the journey of this story from draft to publication? Did you learn anything about yourself as a writer or journalist along the way?

Kelsey: The journey of my story was amazing from the start. I'm a creative person, so I love seeing something come together and evolve. This story took off in the most surprising of ways. Who knew talking about my experience of having a period in prison would become international news! [Editor's

note: The story was co-published by PJP and The Guardian, a British news outlet.] Even though it took over a year from first draft to the final story, through the many (many!) edits and revisions, I enjoyed the entire process.

I learned that what I think and say has importance in the world, and that I matter. I can be a part of a larger conversation. I have the knowledge and ability to make a difference.

INTERVIEW WITH DEREK S. CARTER

[Fighting in War Still Didn't Prepare Me for Prison's Mental Health Crisis](#)

"My first months as a watcher, I discovered the challenges of my new responsibilities. What I saw in the [crisis

stabilization unit] was something more severe and dire than I could have imagined: people who swallowed razors or batteries, lacerated their arms, even one person who shoved a colostomy bag into their abdomen."

Derek was released from prison after his story came out, and we were unable to get in touch with him for this package.

Derek worked on this story for almost a year. It's not uncommon for PJP contributors to have long runways to publication, especially because of challenges with sending mail to and from prison. But Derek's extended time was mostly due to old-fashioned challenges. He revised the story at least five times with the help of myself and a volunteer editor.

At first, Derek's story focused on a South Carolina court case, but with each draft, it moved toward centering people and putting faces on the mental health issues he witnessed in South Carolina prisons. His background in the military and with PTSD added an extra layer of personal experience that brought extra nuance to his understanding of the mental health challenges people face in U.S. prisons.

In a note to us early on, Derek said that he "writes to inspire and teach," and he hoped this story would "aid others who may have sub-par [mental health] treatment in their prison." I think he hit that mark.

— Wyatt Stayner, deputy editor

NOW HIRING FOR THE ECHO

The Echo is accepting applicants for positions as a correspondent. A correspondent works Mon-Fri, hours may vary. This position starts at 11 PRAS points with the opportunity to go up to 13. Correspondents promoted to staff writer can earn 15 points.

Criteria:

- Must be NCI level 2 or 3
- Must work well with staff and AICs of many different backgrounds
- Must have an interest in learning journalism

Duties include:

- Article writing, conducting interviews and researching various topics
- Attending training sessions with outside journalists and other field experts
- Completing homework assignments on AP style writing, news article structure and grammar and punctuation
- Advancement opportunities may include photography and editing duties

To Apply:

Send a communication form (kyte) and a job application to IWP, Journalism Department.

If you completed an application before January, please resubmit.



THE ECHO, VOLUME IX - ISSUE 90, MAY 2026

www.pollenpress.org/the-echo/

Eastern Oregon Correctional Institution

2500 Westgate

Pendleton, OR

97801

WHERE TO FIND THE ECHO AND 1664

ON EDOVO

The Echo and 1664 can be found on the Edovo application.

Readers can find the publications by typing “The Echo” or “1664” into the search bar.

ONLINE

Readers outside the correctional setting can find The Echo and 1664 at www.pollenpress.org or on the Oregon Department of Correction’s webpage under the newsletter directory. Check out www.pollenpress.org/the-echo/



Scanning the QR code will take readers to the ODOC directory of newsletters where The Echo and 1664 are available.

ON UNITS

Print copies of The Echo is available on housing units at Eastern Oregon Correctional Institution. 1664 is available in limited quantities at select locations.

For EOICI, each housing unit has a magazine rack dedicated for The Echo and 1664.

ON TABLETS

The Echo and 1664 can be found in the free section on tablets under “notices.”

The Echo is available at EOICI. 1664 is available at all Oregon prisons.



The Pollen Initiative is dedicated to cultivating media centers inside prisons to shed light on the justice system. Through hands-on multimedia training, as well as leadership programs that facilitate personal growth and transferable skills, our team contributes to more balanced narratives about incarceration.

We support existing prison newsrooms, like the historic San Quentin News, and emerging newsrooms and media projects across the country.

HOW TO DONATE

Support The Echo and 1664 by making a donation to Pollen Initiative.

Donations can be made at www.polleninitiative.org.

Pollen Initiative, EIN 9202619177, is a 501(c)3 tax-exempt organization, and your donation is tax deductible within the guidelines of U.S. law. Please keep your receipt as your official record. We'll email it to you upon successful completion of your donation.